

PC OPTIQUE

DAQ

PCI 6221

OPTIQUE / DAQ

Borniers

CS-68LPR

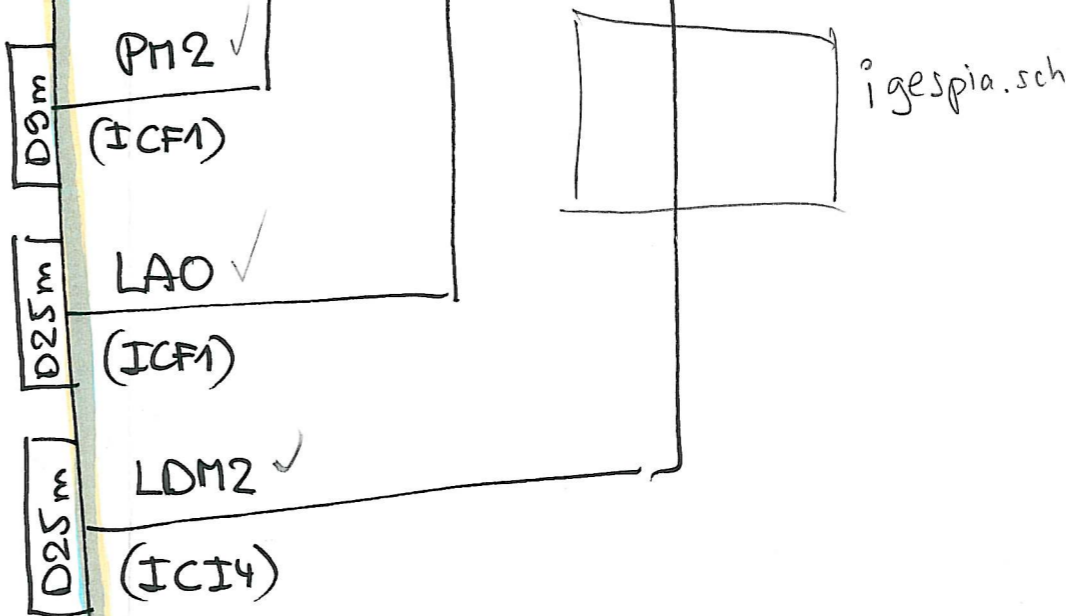

Annexe GAUCHE

CHASSIS DRE

12/5/08

GMI-ADI2A
(Bus optique)

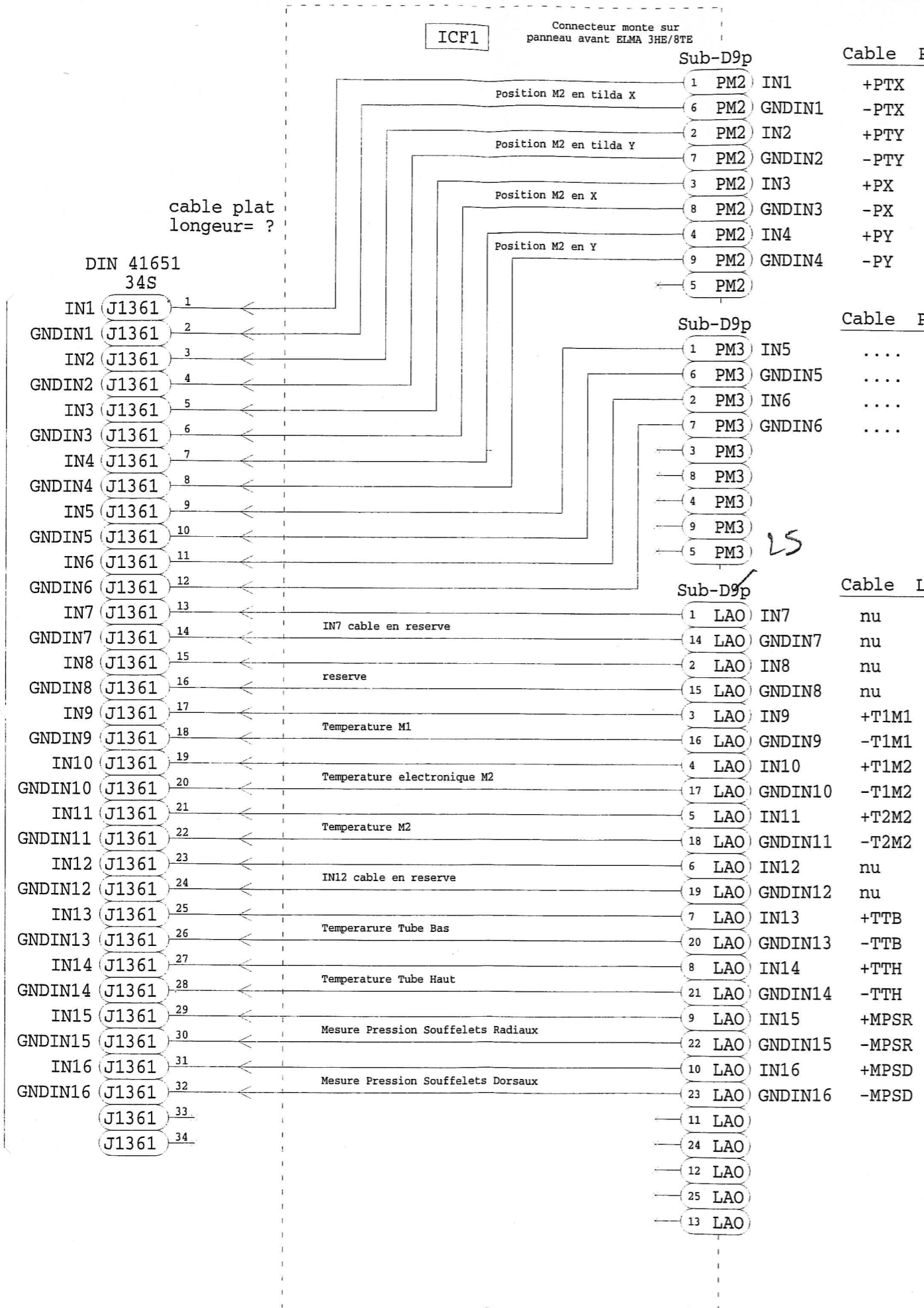

Cable PM2 ✓

BJM2

Cable PM3 ✓

Non Utilise

Cable LAO ✓

RPM

PM2

LAO

R	Observations :	ICF1.sch	Appareil No:		A3
C	Modifications:		Sheet No:		
L	ICF1		Ech.	Dessine	O.Genevay
D	INTERFACE CABLE FOURCHE			Date	19.05.1995
Q	RACK ELECTRONIQUE MONTURE		Page	Etude	E.Ischi
.			1/5	Revise	9.08.2000
.	OBSERVATOIRE DE GENEVE				T4-REM
.	Tel.(022) 755 26 11 / Fax.(022) 755 39 83				

ICI4

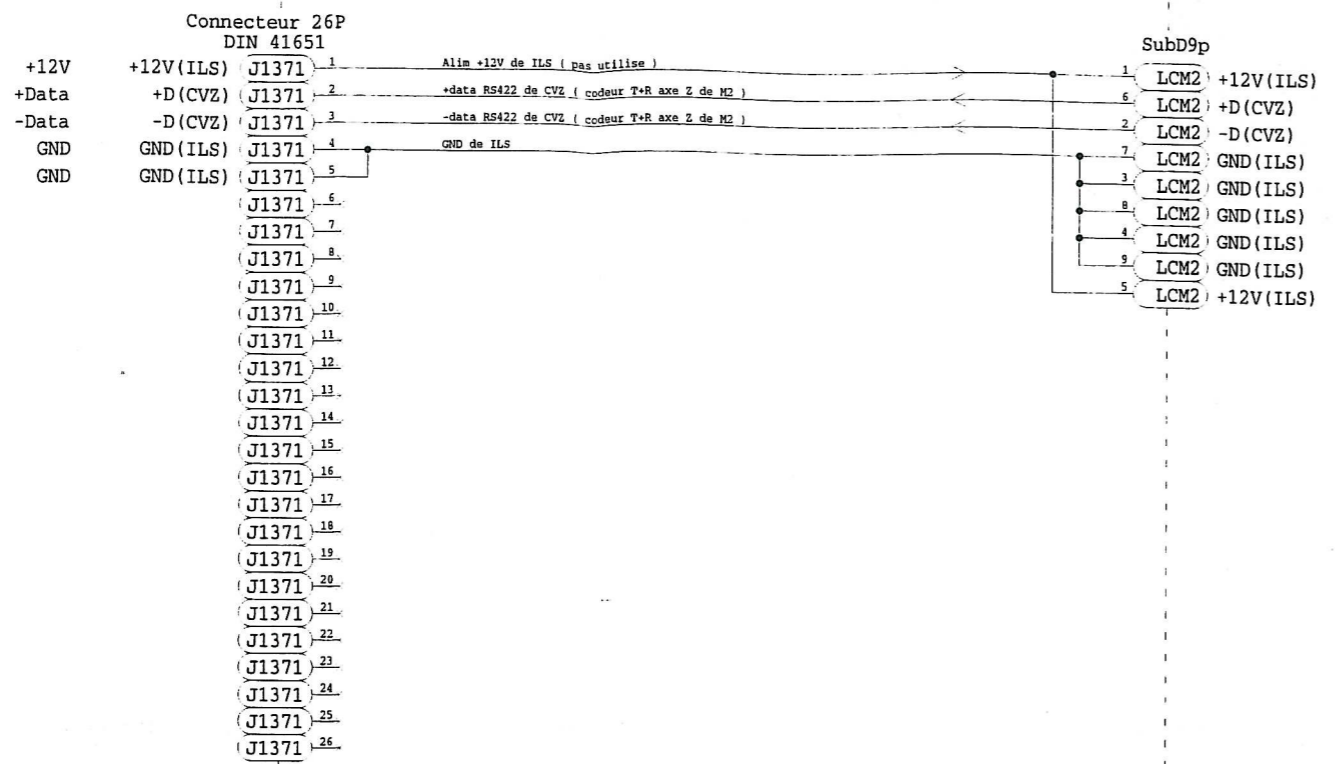

J1371
ILS RS422=>RS232
Bus OPTIQUE

M2 via BJM2

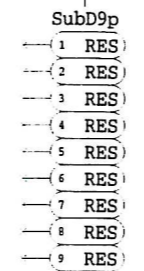

RESERVE

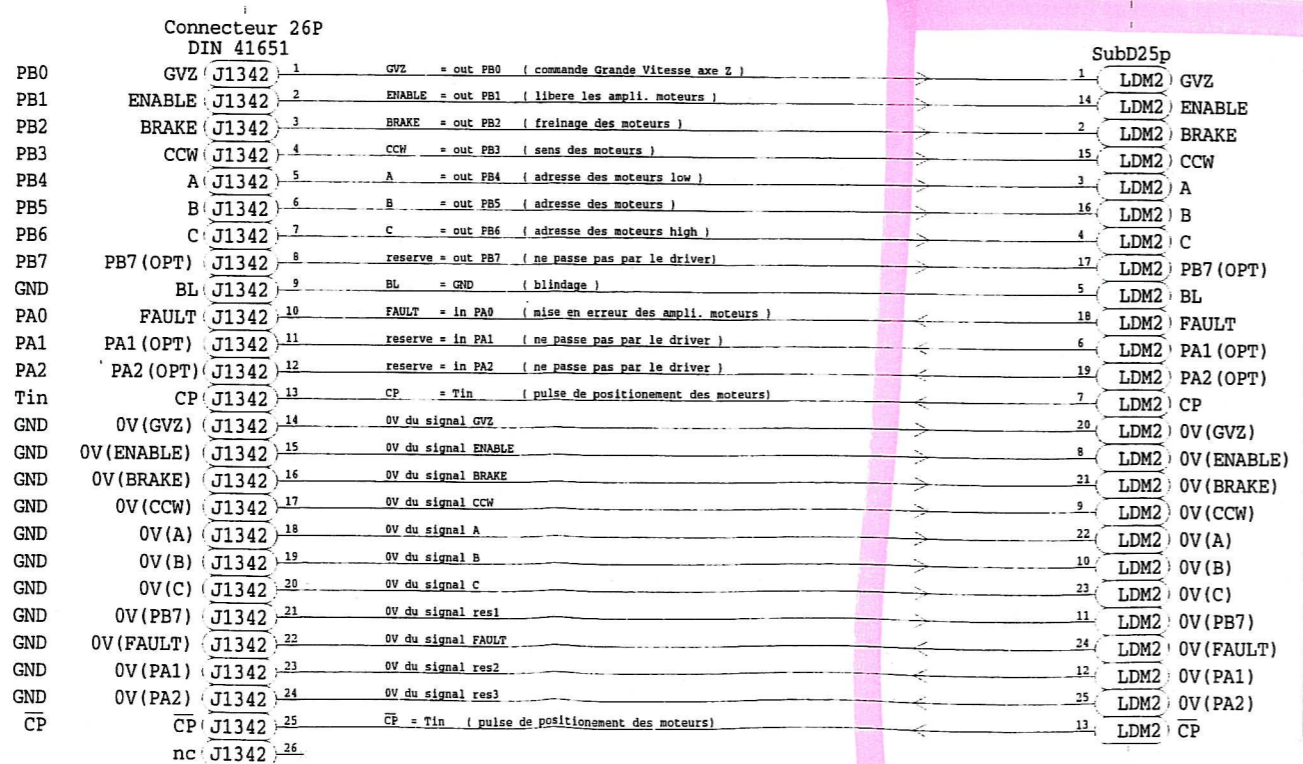

J1342
IGESPIA
Bus OPTIQUE

BJM2 via BJM2

LDM2

Circuit Imprime No: ICI4 180899

R	Observations :	ICI4.sch	Appareil No:		A2
C	Modifications:		Sheet	No:	
L	INTERCONNEXIONS			Ech.	Dessine O.Genevay
D	DES LIAISONS M2			Date	25.08.1999
Q	RACK ELECTRONIQUE MONTURE			Page	Etude E.Ischi
.	OBSERVATOIRE DE GENEVE			4/5	Revise
.	Tel.(022) 755 26 11 / Fax.(022) 755 39 83			T4-REM	

LDM2

GESPIA-12

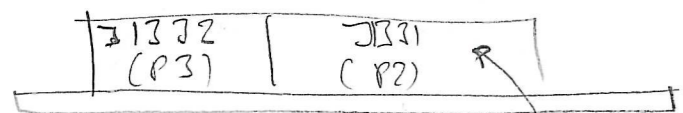

JGESPIA-12

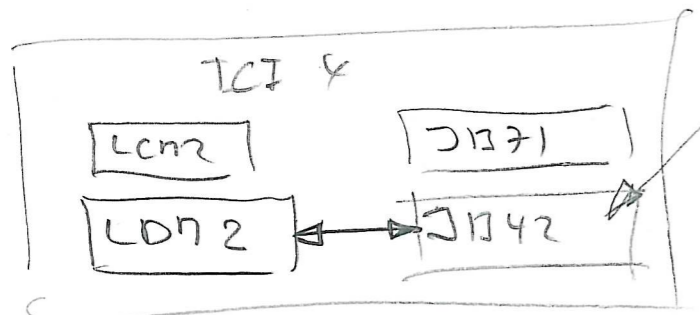
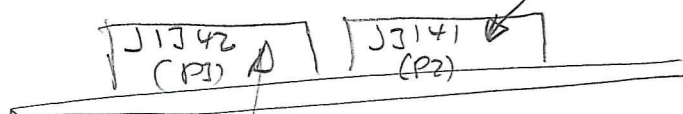

BUS G96

J1331
GESPIA-12

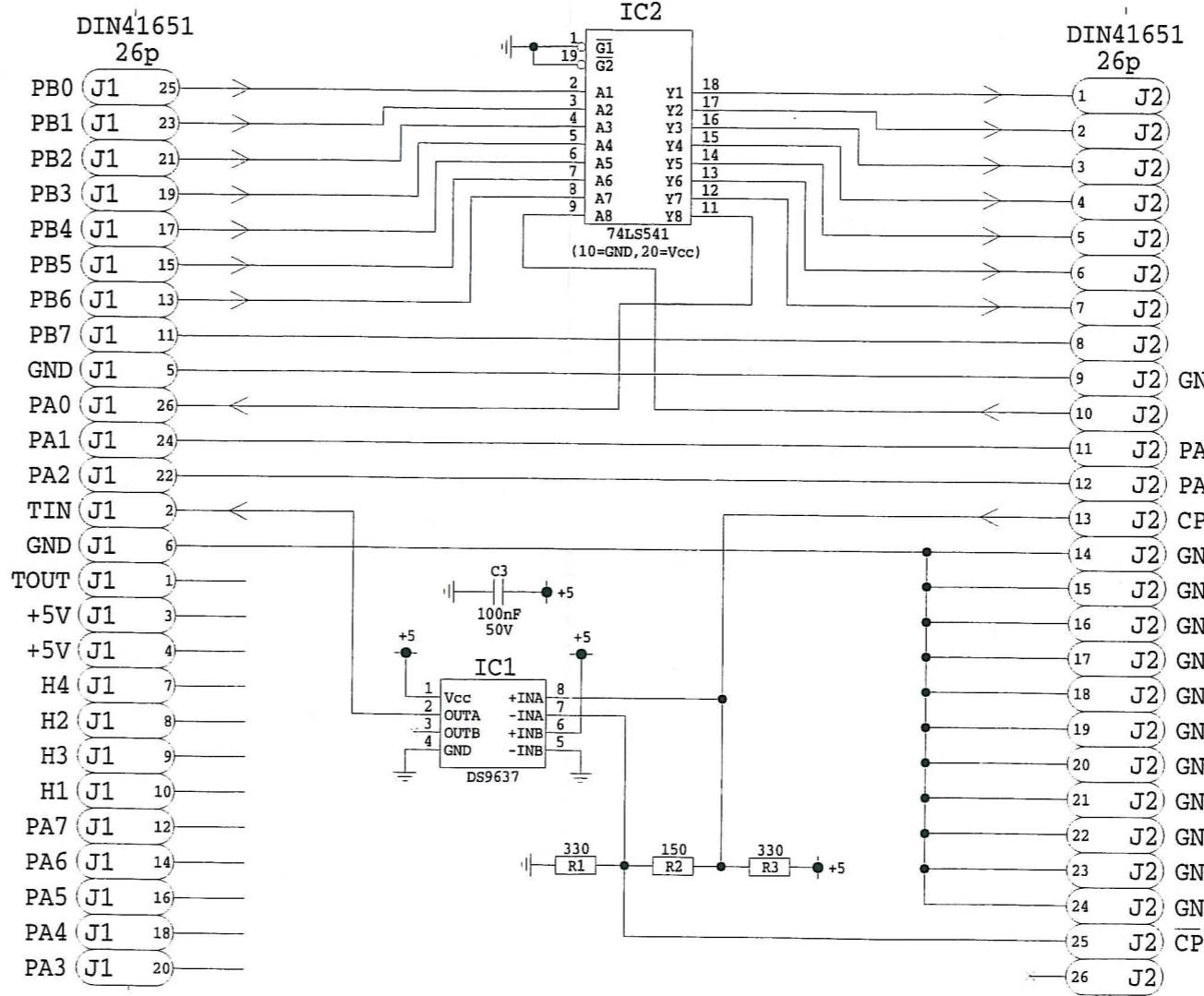
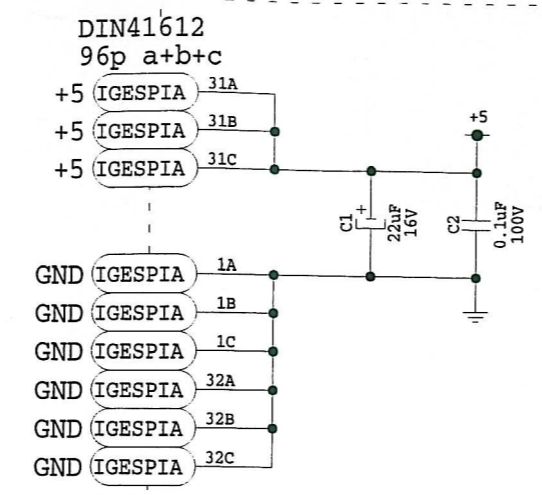

- GVZ
- ENABLE
- BRAKE
- CCW
- A
- B
- C
- NC1
- BLINDAGE
- FAULT
- NC2
- PA1
- NC3
- PA2
- CP
- CP
- 0V-GVZ
- 0V-ENABLE
- 0V-BRAKE
- 0V-CCW
- 0V-A
- 0V-B
- 0V-C
- 0V-NC1
- 0V-FAULT
- 0V-NC2
- 0V-NC3
- CP

J2 ICI4

Appareil No:300596 P134

R	Observations :	igespia.sch	Appareil No:290596
C	Modifications:		Sheet No:
L	BUS OPTIQUE P134.		Ech. Dessine O.Genevay
D	INTERFACE GESPIA-12 <=> M2		Date 23.10.1995
Q	RACK ELECTRONIQUE MONTURE		Page Etude Russiniello
.			././ Revise 23.06.1999
.	OBSERVATOIRE DE GENEVE		T4-REM
.	Tel.(022) 755 26 11 / Fax.(022) 755 39 83		