



HEIDENHAIN

Montageanleitung
Mounting Instructions
Instructions de montage
Istruzioni di montaggio
Instrucciones de montaje

Abtastkopf
Scanning Head
Tête caprice
Testina di scansione
Cabezal
AK ERA 4x70
AK ERA 4x80

2/2014



Inhalt · Contents · Sommaire · Indice · Índice

Allgemeine Warnhinweise
General warning notes
Consignes générales
Avvertenze generali
Advertencias generales



Abmessungen AK ERA 4xx0 mit Teilungstrommel ERA 4x00/4202
Dimensions of ERA 4xx0 scanning head with ERA 4x00/4202 scale drum
Dimensions tête caprice ERA 4xx0 avec tambour gradué ERA 4x00/4202
Dimensioni AK ERA 4xx0 con tamburo ERA 4x00/4202
Dimensiones del cabezal captador AK ERA 4xx0 con tambor graduado ERA 4x00/4202



Abmessungen AK ERA 4xx0 mit Teilungstrommel ERA 4x01
Dimensions of ERA 4xx0 scanning head with ERA 4x01 scale drum
Dimensions tête caprice ERA 4xx0 avec tambour gradué ERA 4x01
Dimensioni AK ERA 4xx0 con tamburo ERA 4x01
Dimensiones del cabezal captador AK ERA 4xx0 con tambor graduado ERA 4x01



Abmessungen für Feinjustagemöglichkeit des AK ERA 4270/4280
Dimensions for possible fine adjustment of the ERA 4270/4280 scanning head
Dimensions pour possibilité de réglage fin de la tête caprice ERA 4270/4280
Dimensioni per possibilità di taratura di precisione del sistema AK ERA 4270/4280
Dimensiones para un posible ajuste de precisión del cabezal captador AK ERA 4270/4280



Anbau Teilungstrommel
Mounting the scale drum
Montage du tambour gradué
Montaggio del tamburo
Montaje del tambor graduado



Anbau AK
Mounting the scanning head
Montage de la tête caprice
Montaggio della testina di scansione
Montaje cabezal



Prüfung der Ausgangssignale / Reinigungshinweise
Checking the output signals / Cleaning Instructions
Contrôle des signaux de sortie / Instructions de nettoyage
Verifica dei segnali in uscita / Istruzioni per la pulizia
Comprobación de las señales de salida / Instrucciones de limpieza



Feinjustage des AK mit 20 µm Teilungsperiode
Fine adjustment of the scanning head with 20-µm grating period
Réglage fin de la tête caprice avec période de division de 20 µm
Taratura di precisione della testina di scansione con passo di divisione di 20 µm
Ajuste de precisión del cabezal con 20 µm de periodo de división



AK ERA 4270/4280

Elektrische und Technische Kennwerte
Electrical data and technical specifications
Caractéristiques électriques et techniques
Dati elettrici e tecnici
Datos eléctricos y técnicos



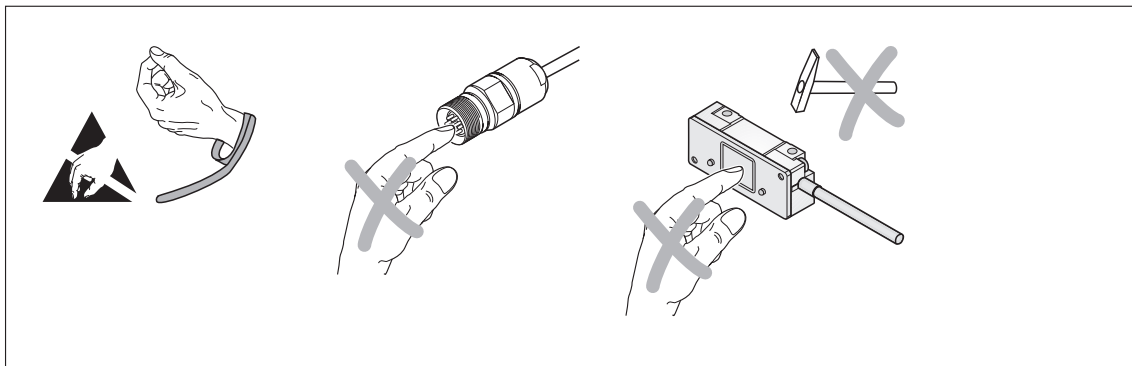

Der direkte Kontakt von Flüssigkeiten mit Messgerät und Steckverbinder ist zu vermeiden!

Avoid direct contact of fluids with the encoder and connector!

Eviter le contact direct de liquides sur le système de mesure et le connecteur!

Evitare che il sistema di misura e il connettore vengano a contatto con liquidi.

¡Evitar el contacto directo de líquidos con el sistema de medida y el conector!

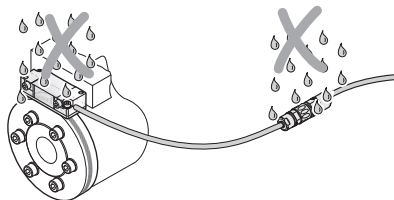



Achtung: Die Montage und Inbetriebnahme ist von einer qualifizierten Fachkraft unter Beachtung der örtlichen Sicherheitsvorschriften vorzunehmen.

Die Steckverbindung darf nur spannungsfrei verbunden oder gelöst werden.

Bei der Montage von AK und Teilungstrommel auch Maße und Hinweise der Montageanleitung der entsprechenden Teilungstrommel ERA 4x0x beachten.

Alle Montageflächen müssen gratfrei und sauber sein.

Angegebene Wellentoleranzen müssen eingehalten werden.

Die Teilungstrommel ist mit allen vorgesehenen Schrauben und Scheiben zu befestigen.

Die Schrauben sind entsprechend der Montageanleitung mit dem angegebenen Anzugsdrehmoment festzuschrauben und gegen unbeabsichtigtes Lösen zu sichern.

Nur dann gelten die für die Teilungstrommeln spezifizierten Drehzahlwerte.

Note: *Mounting and commissioning is to be conducted by a qualified specialist under compliance with local safety regulations.*

Do not engage or disengage any connections while under power.

When mounting the scanning head and the scale drum, please refer to the dimensions and notes in the Mounting Instructions for the respective ERA 4x0x Scale Drum.

All mounting surfaces must be clean and free of burrs.

The specified shaft tolerances must be complied with.

The scale drum is to be fastened with all provided screws and washers.

The screws must be tightened with the specified tightening torque according to the Mounting Instructions, and secured against unintentional loosening.

Only then are the speed values specified for the scale drums valid.



Attention: Le montage et la mise en service doivent être assurés par un personnel qualifié dans le respect des consignes de sécurité locales.

Le connecteur ne doit être branché ou débranché que hors tension.

Lors du montage de la tête caprice et du tambour gradué, tenir compte également des cotes et remarques des Instructions de montage du tambour gradué ERA 4x0x concerné.

Toutes les surfaces doivent être lisses et propres.

Les tolérances indiquées pour l'arbre doivent être respectées.

Le tambour gradué doit être fixé en utilisant toutes les vis et rondelles prévues à cet effet.

Il convient de serrer les vis conformément aux Instructions de montage en respectant le couple de serrage indiqué et de s'assurer qu'elles ne puissent pas se dévisser malencontreusement.

Les valeurs de vitesse de rotation spécifiées pour les tambours gradués ne sont valables qu'à ces conditions.

Attenzione: *Il montaggio e la messa in funzione devono essere eseguite da personale qualificato nel rispetto delle norme di sicurezza locali.*

Collegare o staccare i collegamenti soltanto in assenza di tensione.

Per il montaggio della testina e del tamburo, attenersi anche alle dimensioni e alle indicazioni riportate sulle istruzioni di montaggio del corrispondente tamburo ERA 4x0x. Le superfici di montaggio devono essere prive di graffi e pulite. Devono essere rispettate le tolleranze dell'albero indicate.

Il tamburo deve essere fissato con tutte le viti e le rondelle previste.

Le viti devono essere serrate alla coppia indicata nelle Istruzioni di montaggio e fissate contro l'allentamento involontario.

Solo in tali condizioni sono validi i valori di velocità specificati dei tamburi.



Atención: El montaje y la puesta en marcha deben ser realizados por un especialista cualificado, observando las prescripciones locales de seguridad.

Conectar o desconectar el conector sólo en ausencia de tensión.

Durante el montaje del cabezal captador AK y del tambor graduado prestar atención también a las medidas e indicaciones de las Instrucciones de Montaje del correspondiente tambor graduado ERA 4x0x.

Todas las superficies de montaje deben estar sin rebabas y limpias. Deben respetarse las tolerancias de eje indicadas. El tambor graduado debe fijarse con todos los tornillos y arandelas previstos.

Los tornillos deben apretarse según las Instrucciones de Montaje con el par de apriete indicado y asegurarse para que no se aflojen involuntariamente.

Sólo entonces son válidos los valores de velocidad especificados para los tambores graduados.

mm



Tolerancing ISO 8015

ISO 2768 - m H

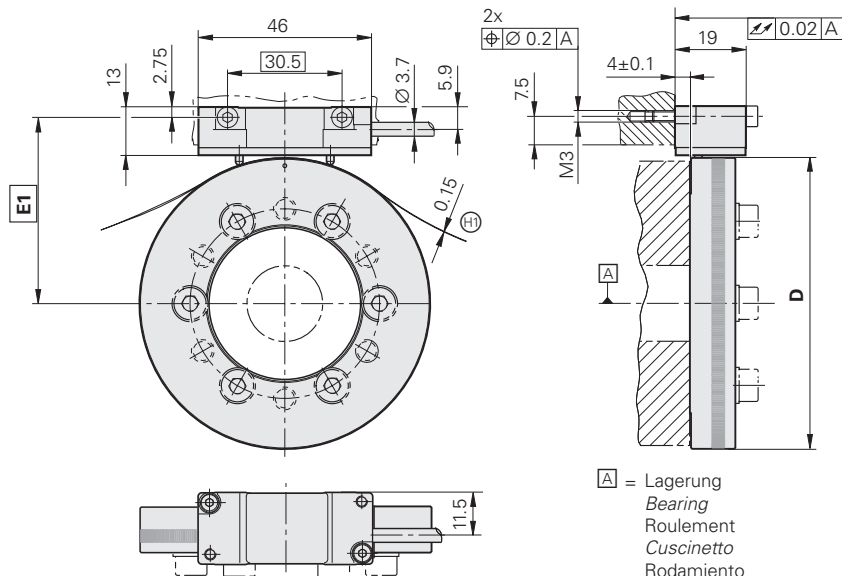
< 6 mm: ± 0.2 mm**AK ERA 4xx0 mit Teilungstrommel ERA 4x00/4202****ERA 4xx0 scanning head with ERA 4x00/4202 scale drum****Tête caprice ERA 4xx0 avec tambour gradué ERA 4x00/4202****AK ERA 4xx0 con tamburo ERA 4x00/4202****Cabezal captador AK ERA 4xx0 con tambor graduado ERA 4x00/4202**

	E1	E2
Ø 76.75	49.34	52.08
Ø 104.63	63.28	66.02
Ø 127.64	74.78	77.52
Ø 178.55	100.24	102.98
Ø 208.89	115.41	118.15
Ø 229.46	125.69	128.43
Ø 254.93	138.43	141.17
Ø 331.31	176.62	179.36
Ø 484.07	253.00	255.74
Ø 560.46	291.19	293.93

Alternative Anbaumöglichkeit
Alternative mounting option
Alternative de possibilité de montage
Possibilità di montaggio alternativa
Posible montaje alternativo

⊕_{H2} = Anschraubfläche Abtastkopf justierbar auslegen
 Ensure adjustability of mounting surface for scanning head
 Surface de vissage tête caprice doit être réglable
 Definire la superficie di montaggio della testina di scansione con possibilità di taratura
 Disponer la superficie de atornillamiento del cabezal captador ajustable

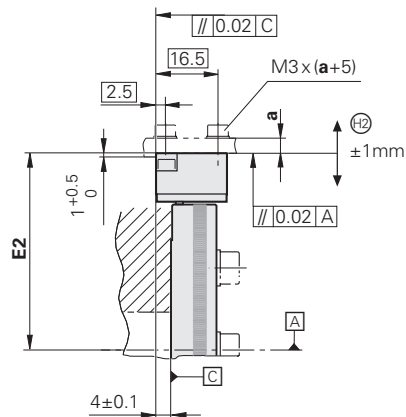
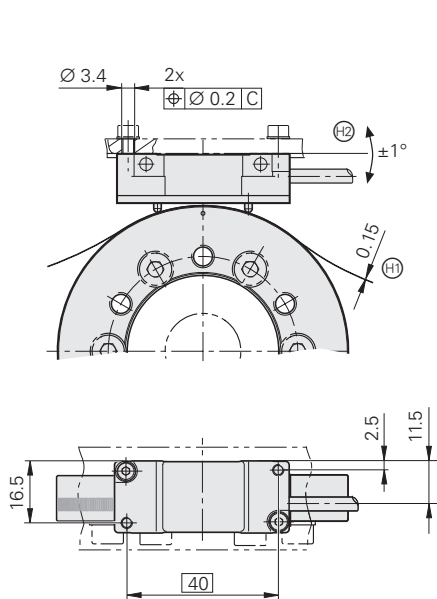

⊕_{H1} = Montageabstand mit Abstandsfolie eingestellt
 Mounting clearance set with spacer foil
 Distance fonctionnelle réglée avec cale d'épaisseur
 Verificata distanza di montaggio con spessimetro
 Distancia de montaje fijada mediante lámina espaciadora

mm



Tolerancing ISO 8015

ISO 2768 - m H

< 6 mm: ±0.2 mm

AK ERA 4xx0 mit Teilungstrommel ERA 4x01

ERA 4xx0 scanning head with ERA 4x01 scale drum

Tête caprice ERA 4xx0 avec tambour gradué ERA 4x01

AK ERA 4xx0 con tamburo ERA 4x01

Cabezal captador AK ERA 4xx0 con tambor graduado ERA 4x01

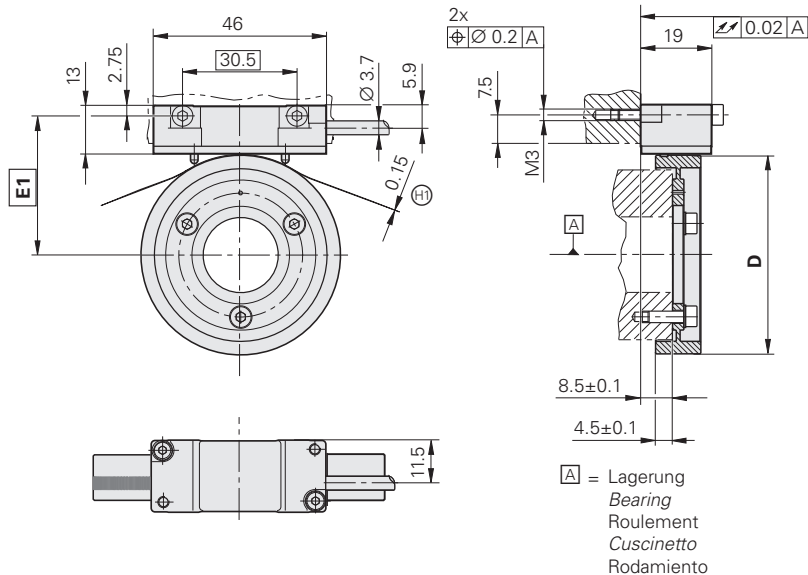

	E1	E2
Ø 52.65	37.29	40.03
Ø 76.75	49.34	52.08
Ø 104.63	63.28	66.02
Ø 114.91	68.42	71.16
Ø 127.64	74.78	77.52
Ø 153.09	87.51	90.25
Ø 208.89	115.41	118.15
Ø 254.93	138.43	141.17
Ø 305.84	163.88	166.62

Alternative Anbaumöglichkeit
Alternative mounting option
Alternative de possibilité de montage
Possibilità di montaggio alternativa
Posible montaje alternativo

Ⓜ2 = Anschraubfläche Abtastkopf justierbar auslegen
 Ensure adjustability of mounting surface for scanning head
 Surface de vissage tête caprice doit être réglable
 Definire la superficie di montaggio della testina di scansione con possibilità di taratura
 Disponer la superficie de atornillamiento del cabezal captador ajustable

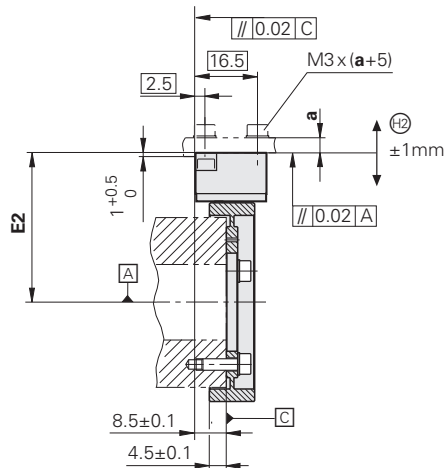
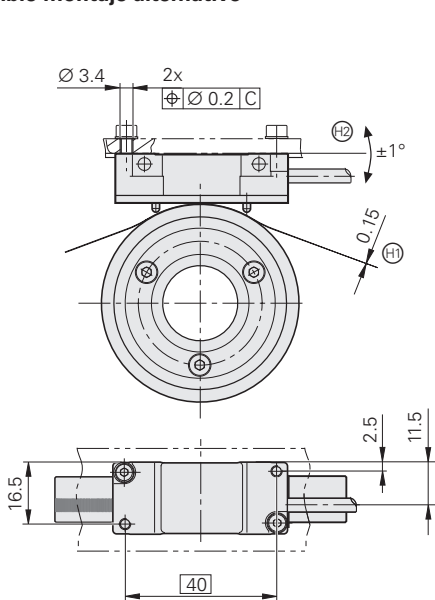

Ⓜ1 = Montageabstand mit Abstandsfolie eingestellt
 Mounting clearance set with spacer foil
 Distance fonctionnelle réglée avec cale d'épaisseur
 Verificata distanza di montaggio con spessimetro
 Distancia de montaje fijada mediante lámina espaciadora

Abmessungen für Feinjustagemöglichkeit des AK ERA 4270/4280 (20 µm Teilungsperiode)

Dimensions for possible fine adjustment of the ERA 4270/4280 scanning head (20-µm grating period)

Cotes pour possibilité de réglage fin de la tête ERA 4270/4280 (période de division 20 µm)

Dimensioni per possibilità di taratura di precisione del sistema AK ERA 4270/4280 (passo di divisione di 20 µm)

Dimensiones para un posible ajuste de precisión del cabezal captador AK ERA 4270/4280 (20 µm de periodo de división)

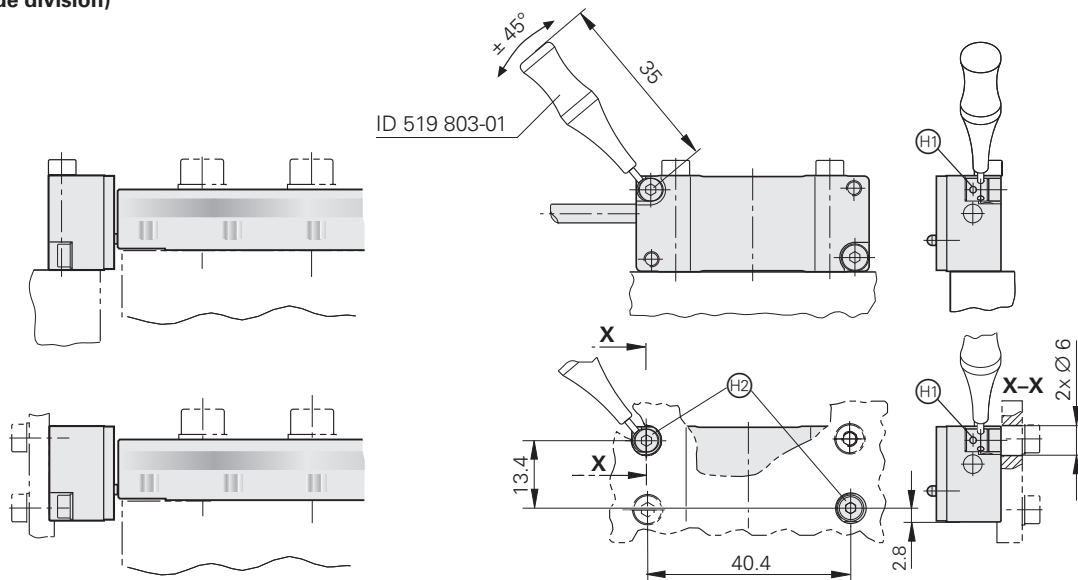

mm



Tolerancing ISO 8015

ISO 2768 - m H

< 6 mm: ± 0.2 mm

Ⓜ1 = Exzenterbuchse (Durchmesser der Justagebohrungen 1.3 mm)
Eccentric nut (diameter of adjustment holes 1.3 mm)
Excentrique (diamètre des perçages de réglage 1.3 mm)
Boccola eccentrica (diametro dei fori di taratura di 1.3 mm)
Casquillo excéntrico (diámetro de los taladros de ajuste 1.3 mm)

Ⓜ2 = Erforderliche Bohrungen zur Feinjustierung
Holes required for fine adjustment
Perçages nécessaires pour le réglage fin
Fori necessari per la taratura di precisione
Taladros necesarios para el ajuste de precisión

siehe Montageanleitung für die entsprechende Teilungstrommel ERA 4x00/ERA 4x01/ERA 4202.
See the Mounting Instructions for the respective ERA 4x00/ERA 4x01/ERA 4202 scale drum.
cf. également Instructions de montage des tambours gradués concernés ERA 4x00/ERA 4x01/ERA 4202.
vedi Istruzioni di montaggio del corrispondente tamburo ERA 4x00/ERA 4x01/ERA 4202.
ver las Instrucciones de Montaje para el correspondiente tambor graduado ERA 4x00/ERA 4x01/ERA 4202.

Teilungstrommel ERA 4200/ERA 4400/ERA 4800.
ERA 4200/ERA 4400/ERA 4800 scale drum.
Tambour gradué ERA 4200/ERA 4400/ERA 4800.
Tamburo ERA 4200/ERA 4400/ERA 4800.
Tambor graduado ERA 4200/ERA 4400/ERA 4800.



ID 592982-9x

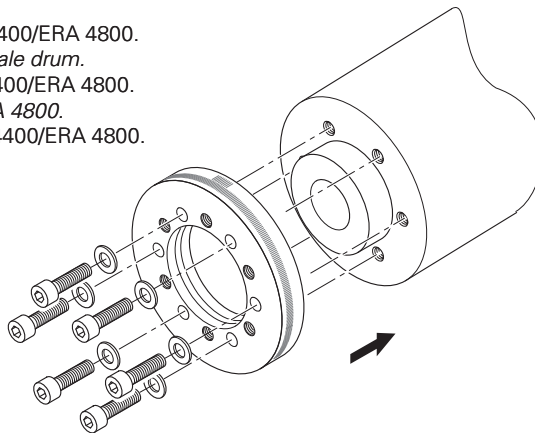

Teilungstrommel ERA 4201/ERA 4401.
ERA 4201/ERA 4401 scale drum.
Tambour gradué ERA 4201/ERA 4401.
Tamburo ERA 4201/ERA 4401.
Tambor graduado ERA 4201/ERA 4401.

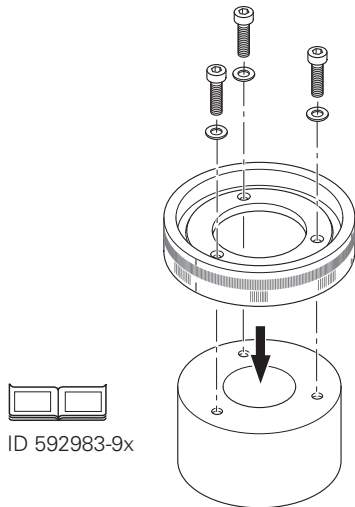

ID 592983-9x

Teilungstrommel ERA 4202.
ERA 4202 scale drum.
Tambour gradué ERA 4202.
Tamburo ERA 4202
Tambor graduado ERA 4202.

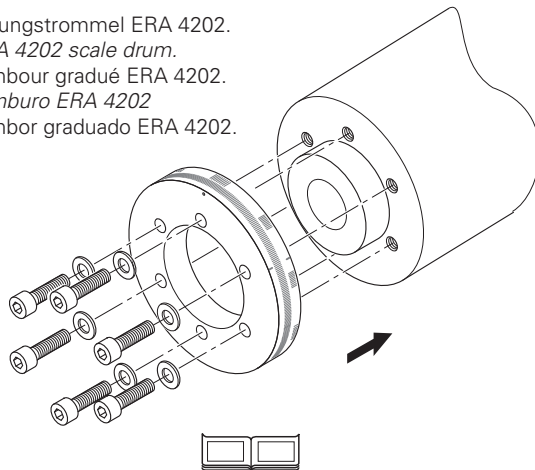

ID 592984-9x

- *)** Auf die Lage der Referenzmarkenspur achten!
Ensure correct position of reference mark track!
 Veiller à la position de la piste de marque de référence!
 Attenzione alla posizione della traccia degli indici di riferimento!
 Tener en cuenta la posición de la pista de marcas de referencia!

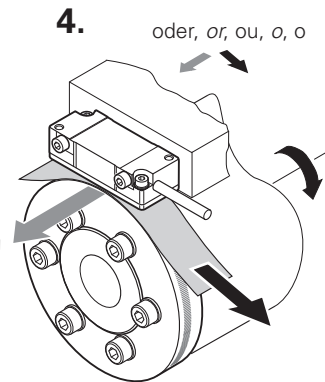
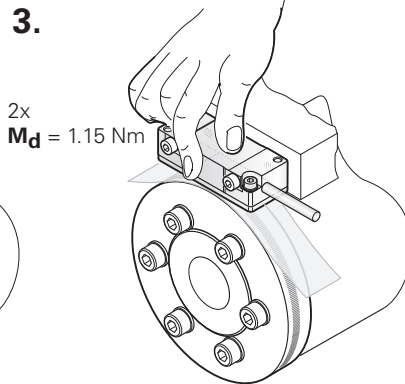
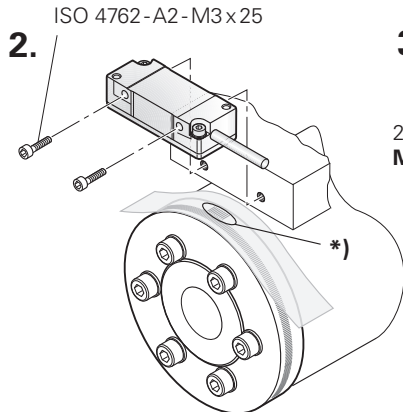
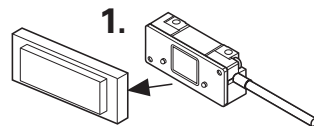

Abtastkopf mit geringer Kraft gegen die Abstandsfolie und Anschraubfläche drücken und festschrauben.
Gently press the scanning head against the spacer foil and the mounting surface and secure it with the screws provided.
 Presser légèrement la tête caprice contre la cale d'épaisseur et la surface de vissage et serrer les vis.
Premere la testina di scansione esercitando una leggera pressione sulla pellicola di montaggio e sulla superficie di avvitamento e fissare.
 Presionar el cabezal captador suavemente contra la lámina separadora y la superficie de atornillamiento, y atornillar.

weitere Montagemöglichkeit:
Other mounting option:
autre possibilité de montage:
altra possibilità di montaggio:
otro posible montaje:

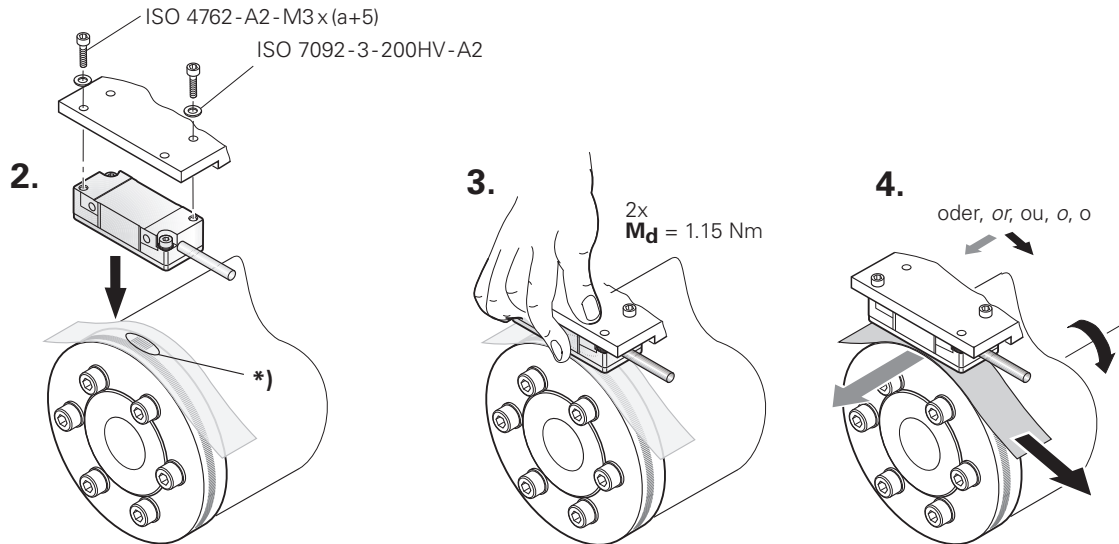

Prüfung der Ausgangssignale
Checking the output signals
Contrôle des signaux de sortie
Verifica dei segnali in uscita
Comprobación de las señales de salida

siehe Betriebsanleitung PWT 1x, ID 319502-9x
see Operating Instructions for PWT 1x, ID 319502-9x
cf. également Mode d'emploi PWT 1x, ID 319502-9x
vedi Manuale di istruzioni del PWT 1x, ID 319502-9x
ver también las Modo de empleo del PWT 1x, ID 319502-9x

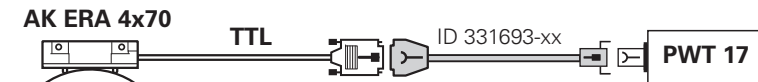

im Lieferumfang PWT 18 enthalten
Included in the items supplied with the PWT 18
contenu dans la fourniture du PWT 18
incluso nello standard di fornitura del PWT 18
incluido en los elementos suministrados del PWT 18

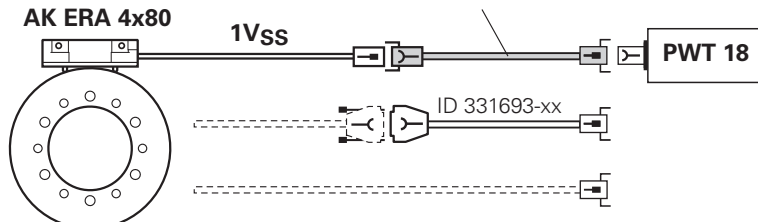

Mit dem PWT kann Signalamplitude, Signalqualität, Lage und Breite der Referenzmarke angezeigt werden.
The PWT shows the signal amplitude, signal quality, position and width of the reference mark in a display window.
 Le PWT permet d'afficher l'amplitude et la qualité du signal, la position et la largeur de la marque de référence.
Il PWT consente di visualizzare ampiezza del segnale, qualità del segnale, posizione e larghezza dell'indice di riferimento.
 Con el PWT pueden visualizarse la amplitud y calidad de la señal, y la posición y anchura de la marca de referencia.

Signalamplitude	Signalqualität
<i>Signal amplitude</i>	<i>Signal quality</i>
Amplitude du signal	Qualité du signal
<i>Ampiezza del segnale</i>	<i>Qualità del segnale</i>
amplitud de la señal	calidad de la seña

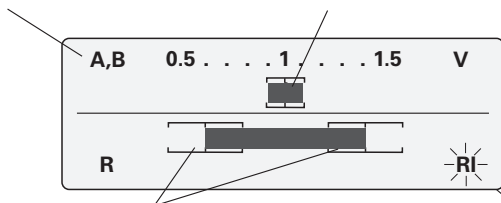

Toleranz des Nulldurchganges der Referenzmarke
Tolerance of zero crossover of the reference mark
 Tolérance du passage à zéro de la marque de référence
Tolleranza del cross-over dell'indice di riferimento
 Tolerancia del paso por cero de la marca de referencia

Messung ist älter als 15 sek.
Measurement is older than 15 seconds
 Mesure antérieure à 15 sec.
Misurazione eseguita da più di 15 sec.
 Medición anterior a 15 seg.

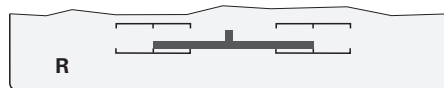

Messung der Referenzmarke
Reference mark measurement
 Mesure marque de référence
Misurazione dell'indice di riferimento
 Medición marca de referencia

Können die angegebenen Justagewerte nicht erreicht werden, Anbautoleranzen überprüfen und Reinigungshinweise beachten, bzw. bei AK mit 20 µm Teilungsperiode Feinjustage durchführen.

If the given adjustment values cannot be achieved, check the mounting tolerances and refer to the cleaning instructions-or make a fine adjustment of scanning heads with 20-µm grating period.

Si les valeurs indiquées pour le réglage ne peuvent pas être atteintes, vérifier les tolérances de montage et les instructions de nettoyage et, avec tête captrice avec période de division de 20 µm, effectuer le réglage fin.

Nel caso non possano essere ottenuti i valori di taratura indicati, controllare le tolleranze di montaggio e attenersi alle istruzioni per la pulizia o, per testina di scansione con passo di divisione di 20 µm, eseguire una taratura di precisione.

Si no se pueden alcanzar los valores de ajuste indicados, comprobar las tolerancias de montaje y prestar atención a las instrucciones de limpieza, o bien, en el caso del cabezal captador con 20 µm de periodo de división, realizar un ajuste de precisión.

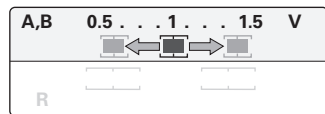
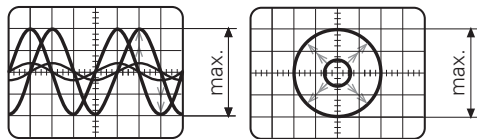

PWT 18 A,B 1 ± 0.2 V
PWT 17 $I_{1,2} 11 \pm 2$ µA

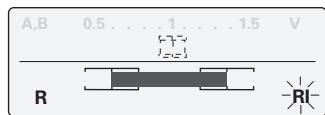

OK ✓

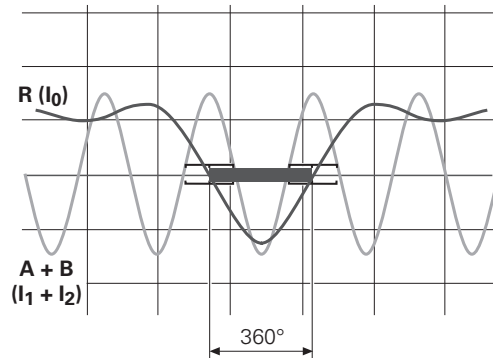

Reinigungshinweise
Cleaning Instructions
Instructions de nettoyage
Istruzioni per la pulizia
Instrucciones de limpieza

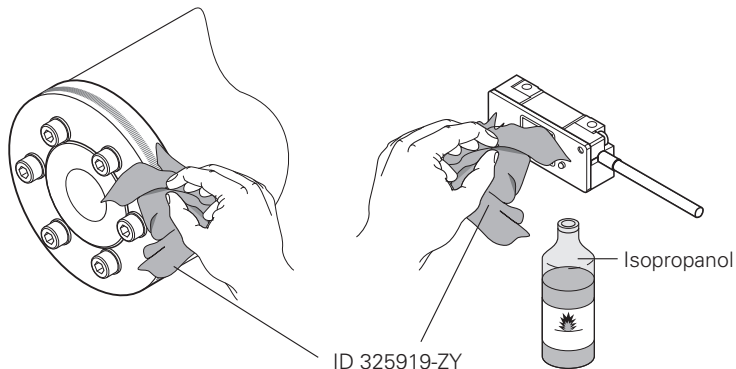

Bei verschmutztem Abtastkopf oder Teilungstrommel Meßgerät mit sauberem fusselfreiem Tuch und Isopropanol vorsichtig reinigen. Feste Partikeln vorher mit Druckluft abblasen.

If the scanning head or scale drum is contaminated, carefully clean the encoder with a clean, lint-free cloth and isopropanol. Remove solid particles with a jet of compressed air first.

Si la tête captrice ou le tambour gradué est sale, nettoyer avec précaution le système de mesure à l'aide d'un chiffon non pelucheux et d'isopropanol. Evacuer auparavant les particules solides à l'aide d'air comprimé.

Con testina di scansione o tamburo contaminato pulire con cura il sistema di misura utilizzando un panno pulito che non lascia pelucchi e isopropanolo. Prima rimuovere lo sporco più consistente con l'aria compressa.

En caso de suciedad en el cabezal captador o en el tambor graduado, limpiar cuidadosamente el sistema de medida con un paño limpio libre de pelusa e isopropanol. Quitar antes las partículas sólidas soplando con aire comprimido.

Feinjustagemöglichkeit des AK ERA 4270/4280 (20 µm Teilungsperiode)
Fine adjustment of the ERA 4270/4280 scanning head (20-µm grating period)
Réglage fin de la tête ERA 4270/4280 (période de division 20 µm)
Taratura di precisione del sistema AK ERA 4270/4280 (passo di divisione di 20 µm)
Ajuste de precisión del cabezal captador AK ERA 4270/4280 (20 µm de periodo de división)

45° bis 60° lösen. Justierbar bei 0.1 Nm.

Loosen the screws one eighth of a turn (45°) to one sixth of a turn (60°) Adjustable at a torque of 0.1 Nm.

Dévisser de 45° à 60°. Réglable à 0.1 Nm.

Allentare da 45° a 60°. Tarabile a 0.1 Nm.

Aflojar 45° a 60°. Ajustable a 0.1 Nm.

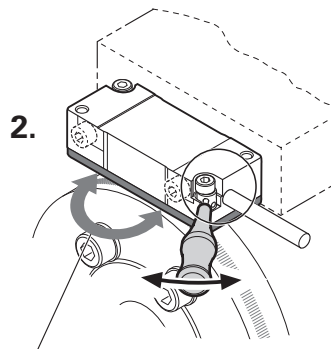
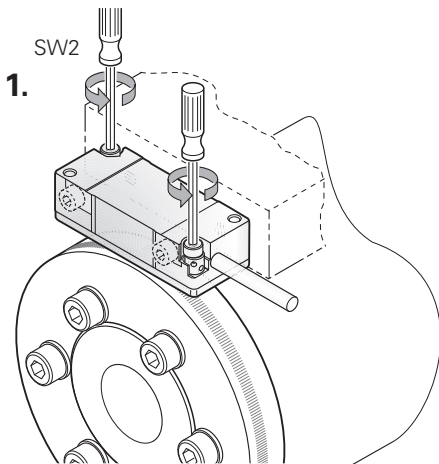

Bewegung der Abtastplatte
Movement of the scanning reticle
Déplacement du réticule de balayage
Movimento della piastra di scansione
Movimiento de la pletina captadora

Exzenterbuchse
Eccentric nut
Excentrique
Boccola eccentrica
Casquillo excéntrico

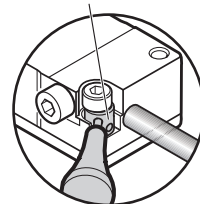

Durch Drehen der Exzenterbuchse können die Inkremental- und Referenzmarkensignale optimiert werden.
(Feinjustage des Abtastfeldes).

*The incremental signals and the reference-mark signals can be optimized by turning the eccentric nut.
(Fine adjustment of the scanning field).*

On peut optimiser les signaux incrémentaux et de la marque de référence en faisant tourner l'excentrique
(réglage fin du champ de balayage).

Ruotando la boccolla eccentrica è possibile ottimizzare i segnali incrementali e di riferimento (taratura di precisione del settore di scansione).

Girando el casquillo excéntrico pueden optimizarse las señales incrementales y las de las marcas de referencia.
(Ajuste de precisión del campo de captación).

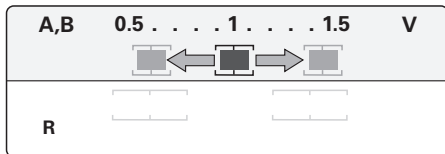
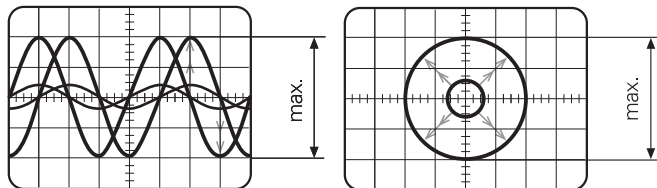

PWT 18 A,B $1 \pm 0.2V$

PWT 17 $I_{1,2} 11 \pm 2 \mu A$

OK ✓

Durch leichtes Verdrehen Referenzmarkenlage justieren. Die Spitze des Referenzmarkensignals soll mit der Spitze des Summensignals fluchten.

Achtung: Amplitude der Inkrementsignale und die Lage des Referenzmarkensignals beachten.

To adjust the position of the reference mark, turn the scanning head slightly. The peak of the reference mark signal should be in line with the peak of the composite signal.

Caution: Pay attention to the amplitude of the incremental signals and the position of the reference-mark signals.

Turner légèrement la tête caprice pour régler la position de la marque de référence. La crête du signal de référence doit être située sur la même ligne que celle du signal composite.

Attention: Tenir compte de l'amplitude des signaux incrémentaux et de la position du signal de référence.

Ruotare leggermente la testina per tarare la posizione dell'indice di riferimento. Il picco del segnale di riferimento deve essere allineato al picco del segnale complessivo.

Attenzione: prestare attenzione all'ampiezza dei segnali incrementali e alla posizione degli indici di riferimento.

Gire el cabezal levemente para ajustar la posición de la marca de referencia. El pico de la señal de las marcas de referencia debe estar alineado con el pico de la señal de las sumas.

Atención: Prestar atención a la amplitud de la señal incremental y a la posición de la señal de la marca de referencia.

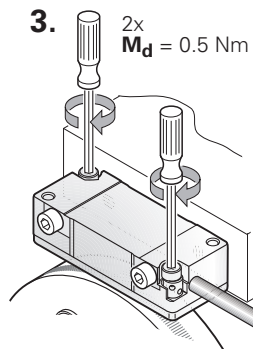
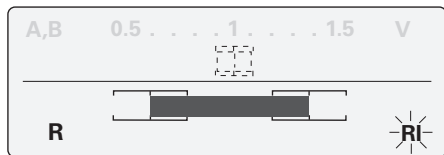
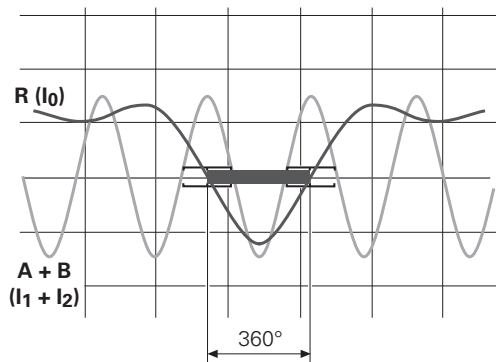

ERA 4x70

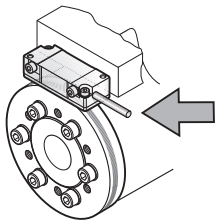

U_p: DC 5V ± 0.5 V
(max. 200 mA)

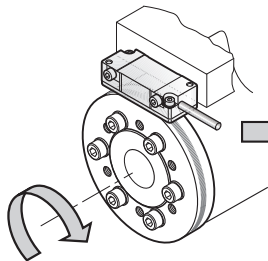

TTL

U_{a1}, U_{a2}, U_{a0}
 $\overline{U_{a1}}, \overline{U_{a2}}, \overline{U_{a0}}, \overline{U_{aS}}$



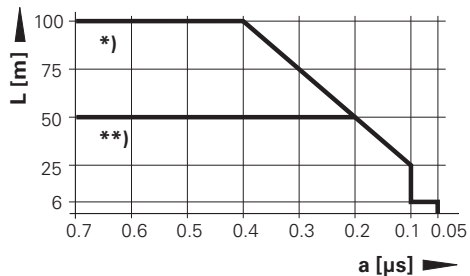
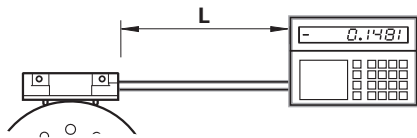

$\overline{U_{aS}}$: Störungssignal
Fault detection signal
 Signal de perturbation
 Segnale di guasto
 Señal de avería

$\overline{U_{aS}} = \text{High}$: ✓

$\overline{U_{aS}} = \text{Low}$: ⚠

*) ohne
without
 sans
 senza
 sin } $\overline{U_{aS}}$

***) mit
with
 avec
 con
 con } $\overline{U_{aS}}$

ERA 4x70



93S15-3K

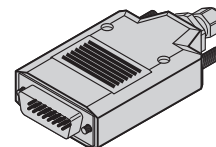
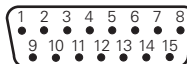

- 1) Im Normalbetrieb mit 0 V der Folgeelektronik verbinden.

Bei Anlegen von 5 V Umschaltung TTL/11 μ Ass.

In normal operation, connect with the 0 V line of the subsequent electronics.

Apply 5 V and switch to TTL/11 μ App.

En fonctionnement normal, relier au 0 V de l'électronique consécutive.

Avec application de 5 V commutation TTL/11 μ ACC.

In funzionamento normale collegare a 0 V dell'elettronica successiva.

Per applicare 5 V commutazione TTL/11 μ App.

En funcionamiento normal conectar con 0 V de la electrónica subsiguiente.

Al aplicar 5 V conmutación TTL/11 μ App.

Schirm auf Gehäuse

Shield on housing

Blindage sur boîtier

Schermo sulla carcassa

Blindaje a carcasa

4	12	2	10	1	9	3	11	14	7	13	15	5, 6, 8
5 V	Sensor U_P	0 V	Sensor 0 V	U_{a1}	$\overline{U_{a1}}$	U_{a2}	$\overline{U_{a2}}$	U_{a0}	$\overline{U_{a0}}$	$\overline{U_{aS}}$	1)	/
●	●	●	●									

Die Sensorleitung ist im Steckverbinder des Messgerätes mit der Versorgungsleitung verbunden.

The sensor line is connected internally with the power supply.

La ligne de palpeur est reliée de manière interne à la ligne d'alimentation.

La linea del sensore è collegata internamente con la linea di alimentazione.

La línea de sensor está unida internamente con la línea de alimentación.

ERA 4x80

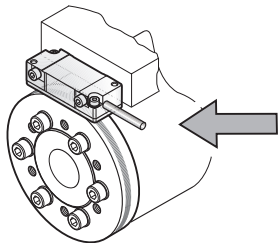

U_p: DC 5 V ± 0.5 V
(max. 100 mA)

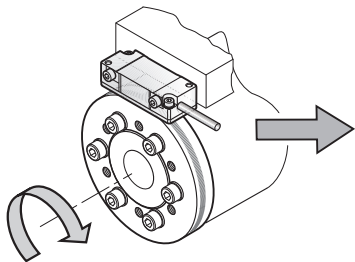

A, B, R

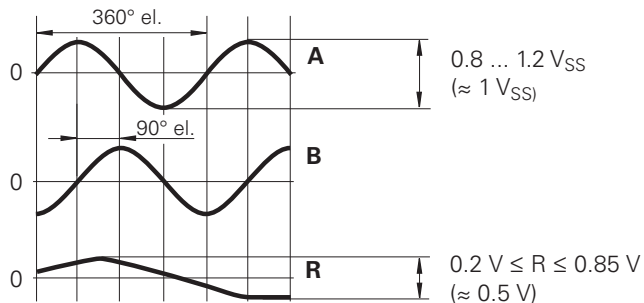

ERA 4x80



01 -H2

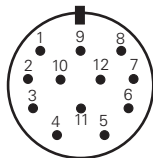

03S12-H2

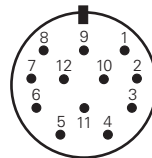
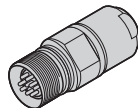

02S12-H2

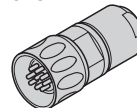

2	12	10	11	5	6	8	1	3	4	7	9	/	/	/	/
5V		0V		A+	A-	B+	B-	R+	R-	/	/	/	/	/	/
brgn BN/GN	wsgn WH/GN	br BN	gn GN	gr GY	rs PK	rt RD	sw BK	/	/	bl BL	ws WH	vio VI	ge YL		

16S15-H1

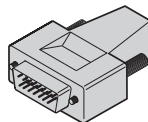
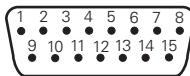



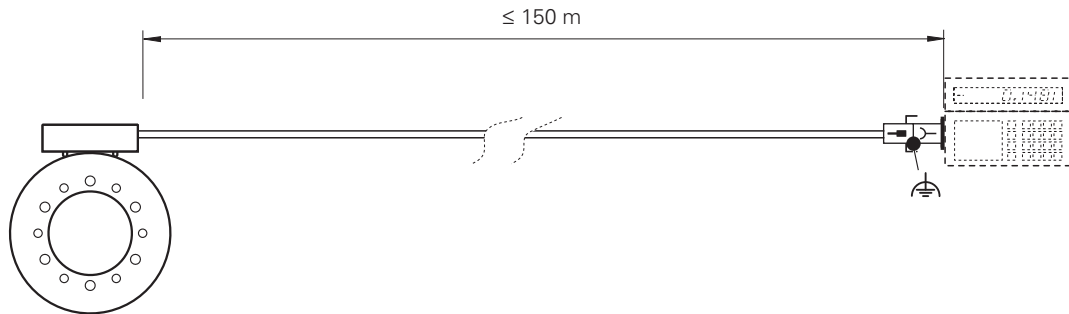

4	12	2	10	1	9	3	11	14	7	8	6	13	5	15
5V		0V		A+	A-	B+	B-	R+	R-	/	/	/	/	/
brgn BN/GN	wsgn WH/GN	br BN	gn GN	gr GY	rs PK	rt RD	sw BK	vio VI	ge YL	bl BL	ws WH	/		

Schirm auf Gehäuse
Shield on housing
Blindage sur boîtier
Schermo sulla carcassa
Blindaje a carcasa

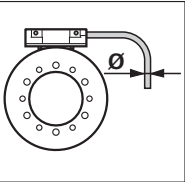
Die Sensorleitung ist im Steckverbinder des Messgerätes mit der Versorgungsleitung verbunden.
The sensor line is connected internally with the power supply.
La ligne de palpeur est reliée de manière interne à la ligne d'alimentation.
La linea del sensore è collegata internamente con la linea di alimentazione.
La línea de sensor está unida internamente con la línea de alimentación.



	 <p>$T \geq -40\text{ °C}$ (40 °F)</p>	 <p>$T \geq -10\text{ °C}$ (14 °F)</p>
<p>Ø 3.7 mm</p>	<p>$R_1 \geq 8\text{ mm}$</p>	<p>$R_2 \geq 40\text{ mm}$</p>
 <p>Ø 8 mm</p>	<p>$R_1 \geq 40\text{ mm}$</p>	<p>$R_2 \geq 100\text{ mm}$</p>

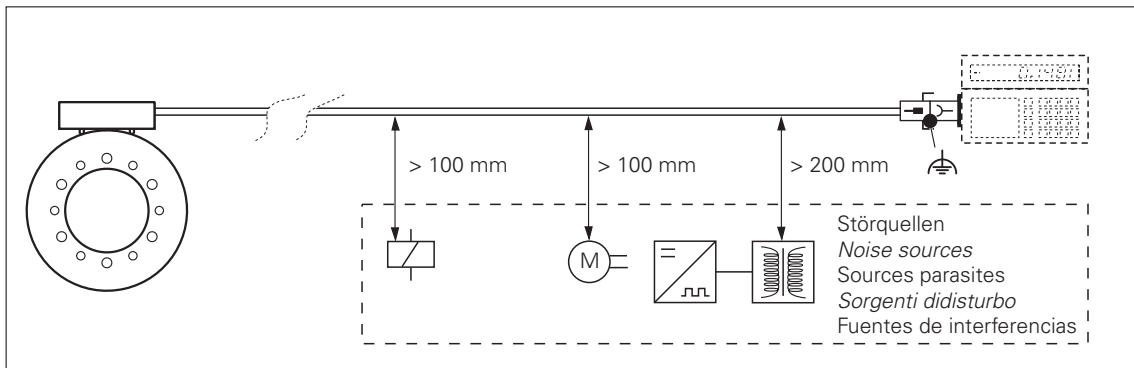

Elektrischen Widerstand zwischen Steckergehäuse und Maschine prüfen.

Sollwert: 1 Ω max.

Check the resistance between the connector housing and the machine.

Desired value: 1 Ω max.

Tester la résistance électrique entre le carter de la prise et la machine.

Valeur nominale: 1 Ω max.

Controllare la resistenza elettrica tra l'alloggiamento del connettore e la macchina.

Valore nominale: 1 Ω max.

Comprobar la resistencia eléctrica entre la carcasa del conector y la máquina.

Valor nominal: 1 Ω máx.

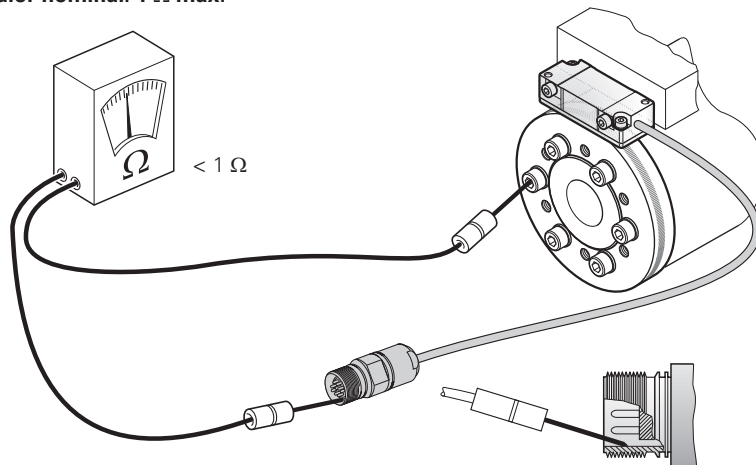

HEIDENHAIN

DR. JOHANNES HEIDENHAIN GmbH

Dr.-Johannes-Heidenhain-Straße 5

83301 Traunreut, Germany

☎ +49 8669 31-0

FAX +49 8669 5061

E-mail: info@heidenhain.de

Technical support FAX +49 8669 32-10 00

Measuring systems ☎ +49 8669 31-31 04

E-mail: service.ms-support@heidenhain.de

TNC support ☎ +49 8669 31-31 01

E-mail: service.nc-support@heidenhain.de

NC programming ☎ +49 8669 31-31 03

E-mail: service.nc-pgm@heidenhain.de

PLC programming ☎ +49 8669 31-31 02

E-mail: service.plc@heidenhain.de

Lathe controls ☎ +49 8669 31-31 05

E-mail: service.lathe-support@heidenhain.de

www.heidenhain.de

