



Orion Weather Station™ User Manual



Orion Weather Station™

User Manual

Version 2.07

Serial Number: _____

Date Purchased: _____

All specifications subject to change without notice.

Printed in U. S. A.

© Copyright 2015 Columbia Weather Systems, Inc. All Rights Reserved.

Proprietary Notice: Orion, Orion LX, Capricorn 2000, Capricorn 2000MP, Capricorn 2000EX, Capricorn FLX, Magellan, Vela and Pulsar Weather Stations are trademarks of Columbia Weather Systems, Inc. The information and drawings contained herein are the sole property of Columbia Weather Systems, Inc. Use of this publication is reserved exclusively for customers of Columbia Weather Systems, Inc. and their personnel. Reproduction of this material is forbidden without the express written consent of Columbia Weather Systems, Inc.

Parts of the Orion Weather Station™ user manual were adapted from the Weather Transmitter WXT520 User's Guide with permission from Vaisala Oyj.

WINDCAP®, RAINCAP®, HUMICAP®, BAROCAP® and THERMOCAP® are registered trademarks of Vaisala.

Welcome!

Congratulations on your purchase of an Orion Weather Station.

Please read this manual completely prior to installation.

Important Notice: Shipping Damage

BEFORE YOU READ ANY FURTHER, please inspect all system components for obvious shipping damage. The Orion is a high precision instrument and can be damaged by rough handling. Your unit was packaged to minimize the possibility of damage in transit. Please save the shipping container for any future shipment of your Orion sensor.

In the event your order arrives in damaged condition, it is important that the following steps be taken immediately. The title transfers automatically to you, the customer, once the material is entrusted to the transport company.

NOTE: DO NOT RETURN THE INSTRUMENT TO COLUMBIA WEATHER SYSTEMS until the following steps are completed. Failure to follow this request will jeopardize your claim.

1. Open the container and inspect the contents. Do not throw away the container or any damaged parts. Try to keep items in the same condition as originally received.
2. Notify the transport company immediately.
3. Request the transport company's representative inspect the shipment personally.
4. After inspection, request a Return Materials Authorization (RMA) from Columbia Weather Systems by calling (503) 629-0887.
5. Return approved items to us at the following address:

Columbia Weather Systems, Inc.

5285 NE Elam Young Parkway, Suite C100

Hillsboro, OR 97124

6. After a repair evaluation, an estimate of the cost of repair will be sent to you.

ESD Protection

Electrostatic Discharge (ESD) can cause immediate or latent damage to electronic circuits. The Orion is adequately protected against ESD for its intended use. However, it is possible to damage the product by delivering electrostatic discharges when touching, removing, or inserting any objects inside the equipment housing.

To avoid delivering high static voltages yourself:

1. Handle ESD sensitive components on a properly grounded and protected ESD workbench. When this is not possible, ground yourself with a wrist strap and a resistive connection cord to the equipment chassis before touching the boards. When neither of the above is possible, at least touch a conductive part of the equipment chassis with your other hand before touching the boards.
2. Always hold the boards by the edges and avoid touching the component contacts.

Table of Contents

WELCOME!	3
IMPORTANT NOTICE: SHIPPING DAMAGE	5
ESD PROTECTION	6
SECTION 1: INTRODUCTION	11
THE ORION WEATHER STATION	11
SPECIFICATIONS	12
<i>Operating Conditions</i>	12
<i>Wind Speed</i>	12
<i>Wind Direction</i>	12
<i>Relative Humidity</i>	12
<i>Temperature</i>	13
<i>Barometric Pressure</i>	13
<i>Precipitation</i>	13
<i>Input Voltage</i>	14
<i>Heating Power Source</i>	14
<i>Sensor Housing</i>	14
PRINCIPLES OF MEASUREMENTS	15
<i>Wind Measurement</i>	15
<i>Barometric Pressure, Temperature, and Humidity (PTU) Module</i>	16
<i>Rainfall Measurement</i>	17
SECTION 2: PHYSICAL DESCRIPTION	19
ORION SENSOR TRANSMITTER	19
<i>Sensor Transmitter Components</i>	19
<i>Sensor Transmitter Dimensions</i>	21
<i>Mounting Adapter</i>	23
<i>Internal Terminal Block</i>	24
<i>Heating (Optional)</i>	25
<i>Interface Module</i>	26
SURGE/LIGHTNING PROTECTOR	27
WEATHERMASTER™ SOFTWARE (OPTIONAL)	28
WEATHER DISPLAY CONSOLE (OPTIONAL)	29
WEATHER MICROSERVER (OPTIONAL)	30
SECTION 3: FIXED MOUNT INSTALLATION	31
FIXED MOUNT SYSTEM CONFIGURATIONS	31
INSTALLATION OVERVIEW	33
UNPACKING THE UNIT	33
<i>Installing the Mast</i>	35
<i>Location</i>	35

<i>Mounting Method</i>	35
<i>Routing Cable</i>	35
<i>Installing the Orion Sensor Transmitter</i>	37
<i>Site Selection:</i>	37
<i>Installing the Mounting Adapter</i>	37
<i>North Alignment</i>	38
<i>Installing the Surge Arrestor</i>	39
<i>Connecting the Sensor Transmitter to the Interface Module</i>	40
OPTIONAL SENSOR MOUNTING HARDWARE	41
<i>Telescoping Tripod and Tiedown Kit</i>	41
<i>Specifications</i>	42
<i>Sensor Mast</i>	43
<i>Roof Mounting</i>	43
<i>Wall Mounting</i>	44
SECTION 4: VEHICLE MOUNT INSTALLATION	47
VEHICLE MOUNT SYSTEM CONFIGURATIONS	47
INSTALLATION OVERVIEW	47
UNPACKING THE UNIT	48
INSTALLING THE TELESCOPING MAST AND VEHICLE-MOUNT BRACKETS	49
INSTALLING VEHICLE MOUNT SENSOR CONNECTOR AND ROUTING CABLE	51
INSTALLING THE INTERFACE MODULE.....	51
CONNECTING THE WEATHER DISPLAY CONSOLE AND COMPUTER	52
INSTALLING THE SENSOR TRANSMITTER AND NORTH ORIENTATION	53
<i>Installing the Mounting Adapter</i>	53
<i>North Alignment</i>	54
SECTION 5: ORION NOMAD PORTABLE INSTALLATION	57
ORION NOMAD SYSTEM CONFIGURATIONS	57
UNPACKING THE UNIT	59
<i>Orion Carrying Case</i>	61
TELESCOPING TRIPOD AND TIEDOWN KIT	62
<i>Tripod Parts List:</i>	63
<i>Specifications</i>	64
<i>RS-232 Interface Module</i>	65
<i>Installing the Mounting Adapter</i>	66
SET UP INSTRUCTIONS.....	66
<i>Site Selection:</i>	66
<i>Mast Set Up and Sensor Alignment:</i>	67
<i>Transportation Case and Sensor Plug-In</i>	69
<i>Battery Power System</i>	69
OPERATION.....	69
MONITORING	70
SECTION 6: OPERATION	71

<i>Orion Sensor Data Output Definition</i>	71
<i>Wind data</i>	71
<i>PTU Data</i>	72
<i>Precipitation Data:</i>	72
<i>Supervisory Data:</i>	72
CONNECTING THE ORION SENSOR TO A COMPUTER	73
CONNECTING THE ORION SENSOR TO THE WEATHER MICROSERVER	74
CONNECTING THE ORION SENSOR TO THE WEATHER DISPLAY CONSOLE	75
<i>CRC-16 Computation</i>	76
<i>Encoding the CRC as ASCII Characters</i>	77
SECTION 7: CALIBRATION	79
FACTORY CALIBRATION	79
TEMPERATURE AND PRESSURE READING ADJUSTMENTS	79
SECTION 8: MAINTENANCE	81
CLEANING	81
REPLACING THE PTU MODULE	81
FACTORY CALIBRATION AND REPAIR SERVICE	82
SECTION 9: TROUBLESHOOTING	83
<i>Loss of communication with Orion sensor module:</i>	84
<i>Wind measurement failure:</i>	84
<i>Pressure, humidity and temperature measurement failure:</i>	84
SECTION 10: USER SUPPORT INFORMATION	85
LIMITED WARRANTY	85
<i>EXCLUSIONS</i>	85
RETURN FOR REPAIR PROCEDURE	86
REFERENCE	88
GLOSSARY	88
<i>Aspirating Radiation Shield</i>	88
<i>Barometric Pressure</i>	88
<i>Celsius Temperature Scale</i>	88
<i>Dew Point</i>	88
<i>Density Altitude</i>	88
<i>Fahrenheit Temperature Scale</i>	88
<i>Global Radiation</i>	89
<i>Heat Index</i>	89
<i>Pyranometer</i>	89
<i>Relative Humidity</i>	89
<i>Sea Level Pressure</i>	89
<i>Solar Radiation</i>	89
<i>Wind Chill</i>	89
UNIT CONVERSION	90

<i>Speed</i>	90
<i>Temperature</i>	90
<i>Distance</i>	90
<i>Pressure</i>	90
TABLES AND FORMULAS.....	91
<i>Wind Chill Chart</i>	91
<i>Wind Chill Equation</i>	92
<i>Heat Index</i>	93
<i>Dew Point</i>	94

SECTION 1: INTRODUCTION

The Orion Weather Station

The Orion weather station provides ultrasonic wind direction and speed measurements, a highly-accurate impact rain sensor, capacitive relative humidity, temperature and barometric pressure readings – all in a single sensor module.

High accuracy and fine resolution make this system ideal for precision weather monitoring.

Available in three configurations – fixed-mount, vehicle-mount, and the Orion Nomad™ portable weather station – Orion data can be monitored with our proprietary Weather Display Console and WeatherMaster™ Software, as well as with third-party software.

The Weather MicroServer is available for Ethernet connectivity, Modbus/TCP, Modbus RTU and SNMP interface, Weather Underground, Anything Weather and CWOP interface, XML weather data, and FTP.

Specifications

Operating Conditions

Temperature Operation: -52 to +60°C (-61 to +140°F)

Relative humidity: 0 to 100%

Pressure: 600 to 1100 hPa

Wind: 0 to 60 m/s

* Due to the measurement frequency used in the sonic transducers, RF interference in the 200-400kHz range can disturb wind measurement.

Wind Speed

Range: 0-135mph (0-60 m/s)

Accuracy: $\pm 3\%$ at 10 m/s

Resolution: 1 mph (1 m/s)

Units Available: knots, mph, km/hr, m/s

Wind Direction

Azimuth: 0-360°

Accuracy: $\pm 3^\circ$

Resolution: 1°

Units Available: °Azimuth

Relative Humidity

Range: 0 - 100%

Accuracy: $\pm 3\%$ (0-90%), 5% (90-100%)

Resolution: 1%

Units Available: %RH

Temperature

Range: -60 to 140 °F (-52 to +60 °C)

Accuracy: ± 0.5 °F (± 0.3 °C) at 68 °F (+20 °C)

Resolution: 0.1 °F

Units Available: °F, °C

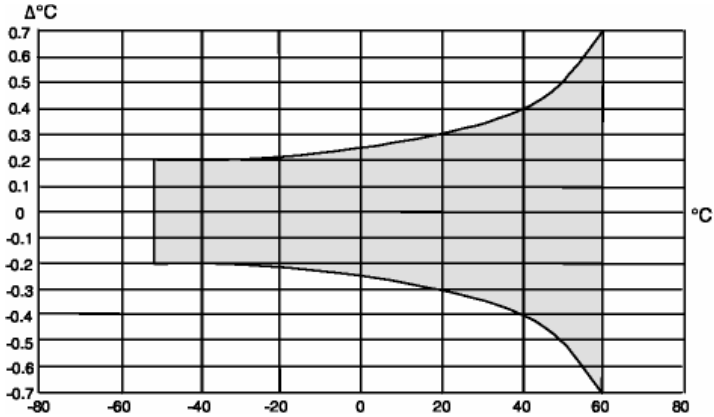

Barometric Pressure

Range: 17.50 to 32.50 InHg (600 to 1100 hPa)

Accuracy: ± 0.015 InHg (0.5 hPa) at +32 to 86 °F (0 to 30 °C)
 ± 0.03 InHg (1 hPa) at -60 to 140 °F (-52 to 60 °C)

Resolution: 0.01 InHg (0.1 hPa)

Units Available: Kpa, mbar, InHg

Precipitation

Range: cumulative

Collection Area: 602cm

Accuracy: $\pm 5\%$ (spatial variations may exist)

Resolution 0.01 in. (0.254mm)

Units Available: mm, inches

Input Voltage

The Orion is supplied with a wall mount switching power supply

Input: 100 - 240 VAC, 50/60 HZ, 0.6A

Output: 12 VDC, 1.25A

The Orion can also be powered directly using a DC voltage source

Input: 5 to 30 VDC (60 mA at 12 VDC) for unheated models

Heating Power Source

Input: 5 to 30 VDC (1.1 A at 12 VDC)

Sensor Housing

Protection class: IP66 (with mounting adapter)

Materials: Polycarbonate + 20% glass fiber, stainless steel (AISI 316)

Weight: 650 g (1.43 lbs)

Principles of Measurements

Wind Measurement

Both wind speed and direction are measured using advanced ultrasonic technology. The sensor utilizes ultrasound to determine horizontal wind readings. The array of three equally-spaced ultrasonic transducers on a horizontal plane is an ideal design that ensures accurate wind measurement from all directions, without blind angles or corrupted readings.

The wind sensor has no moving parts, which makes it virtually maintenance free.

Wind speed and wind directions are determined by measuring the time it takes the ultrasound to travel from each transducer to the other two.

The wind sensor measures the transit time (in both directions) along the three paths established by the array of transducers. This transit time depends on the wind speed along the ultrasonic path. For zero wind speed, both the forward and reverse transit times are the same. With wind along the sound path, the up-wind direction transit time increases and the down-wind transit time decreases.

The wind speed is calculated from the measured transit times using the following formula:

$$V_w = 0.5 \times L \times (1/t_f - 1/t_r)$$

where:

V_w = Wind speed

L = Distance between the two transducers

t_f = Transit time in forward direction

t_r = Transit time in reverse direction

Measuring the six transit times allows V_w to be computed for each of the three ultrasonic paths. The computed wind speeds are independent of altitude, temperature and humidity, which are cancelled out when the transit times are measured in both directions, although the individual transit times depend on these parameters.

Using V_w values of two array paths is enough to compute wind speed and wind direction. A signal processing technique is used so that wind speed and wind direction are calculated from the two array paths of best quality.

The wind speed is represented as a scalar speed in selected units (m/s, kt, mph, km/h). The wind direction is expressed in degrees (°). The wind

direction reported indicates the direction that the wind comes from. North is represented as 0°, east as 90°, south as 180°, and west as 270°.

The wind direction is not calculated when the wind speed drops below 0.05 m/s. In this case, the last calculated direction output remains until the wind speed increases again to the level of 0.05 m/s.

The average values of wind speed and direction are calculated as a scalar average of all samples over the selected averaging time (1 ... 900 s). The sample count is based on a 4 Hz sampling rate. The minimum and maximum values of wind speed and direction represent the corresponding extremes during the averaging time.

Barometric Pressure, Temperature, and Humidity (PTU) Module

Barometric pressure, temperature, and humidity measurements are combined in an advanced sensor module (PTU) utilizing a capacitive measurement method for each parameter. The PTU module contains separate sensors for pressure, temperature, and humidity measurement.

The measurement principle of the pressure, temperature, and humidity sensors is based on an advanced RC oscillator and two reference capacitors against which the capacitance of the sensors is continuously measured. The microprocessor of the transmitter performs compensation for the temperature dependency of the pressure and humidity sensors.

Barometric pressure is measured using a capacitive silicon BAROCAP® sensor. The sensor has minimal hysteresis and excellent repeatability, as well as outstanding temperature and long-term stability.

Temperature is measured with a capacitive ceramic THERMOCAP® sensor.

Relative humidity measurement is based on a capacitive thin film polymer HUMICAP®180 sensor. The sensor is highly accurate with negligible hysteresis and excellent long-term stability in a wide range of environments.

Radiation Shield: This module is mounted in a specially-designed radiation shield which protects the sensors from both scattered and direct sunlight and precipitation. The composite material in the plates offers excellent thermal characteristics and UV stabilized construction. The white outer surface reflects radiation, while the black inside absorbs accumulated heat.

The internal sensor module is easily replaceable and readily available as a spare component. To order a replacement module, please use Part No. 9581.

Rainfall Measurement

Rainfall is measured with an impact sensor, which detects the size and impact of individual rain drops. The signals resulting from the impacts are proportional to the volume of the drops. Hence, the signal from each drop can be converted directly to the accumulated rainfall.

This measurement method eliminates flooding and clogging, as well as wetting and evaporation losses.

The sensor transmitter uses RAINCAP® sensor 2 technology in precipitation measurement.

The precipitation sensor is comprised of a steel cover and a piezoelectric sensor mounted on the bottom surface of the cover.

The precipitation sensor detects the impact of individual raindrops. The signals from the impact are proportional to the volume of the drops. Advanced noise filtering technique is used to filter out signals originating from other sources than raindrops.

The measured parameter is accumulated rainfall. Detection of each individual drop enables computing of rain amount with high resolution.

SECTION 2: PHYSICAL DESCRIPTION

Orion Sensor Transmitter

The Orion Sensor Transmitter is an all-in-one sensor unit containing ultrasonic wind speed and direction sensor, temperature sensor, relative humidity sensor, barometric pressure sensor and an impact rain sensor.

The temperature, relative humidity and barometric pressure sensors are combined in a single module housed in a self-aspirating radiation shield.

Sensor Transmitter Components

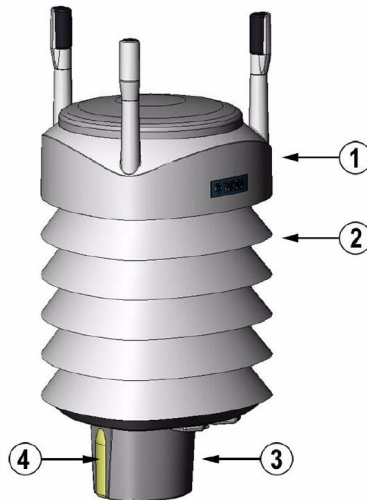

- 1: Top of the transmitter
- 2: Radiation Shield
- 3: Bottom of the transmitter
- 4: Screw cover

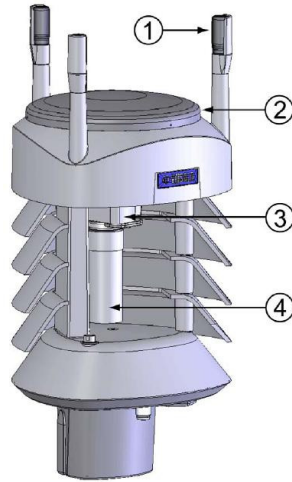

Cut Away View

- 1: Wind Transducers (3 pcs)
- 2: Precipitation Sensor
- 3: Pressure sensor inside the Sensor Module
- 4: Humidity and temperature sensor inside the Sensor Module

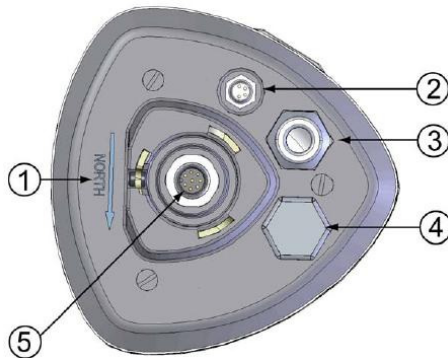

Bottom of the Transmitter

- 1: Alignment direction sign
- 2: Service port
- 3: Watertight cable gland
- 4: Unused cable gland, covered
- 5: Optional M12 connector

Sensor Transmitter Dimensions

Dimensions in mm (inches)

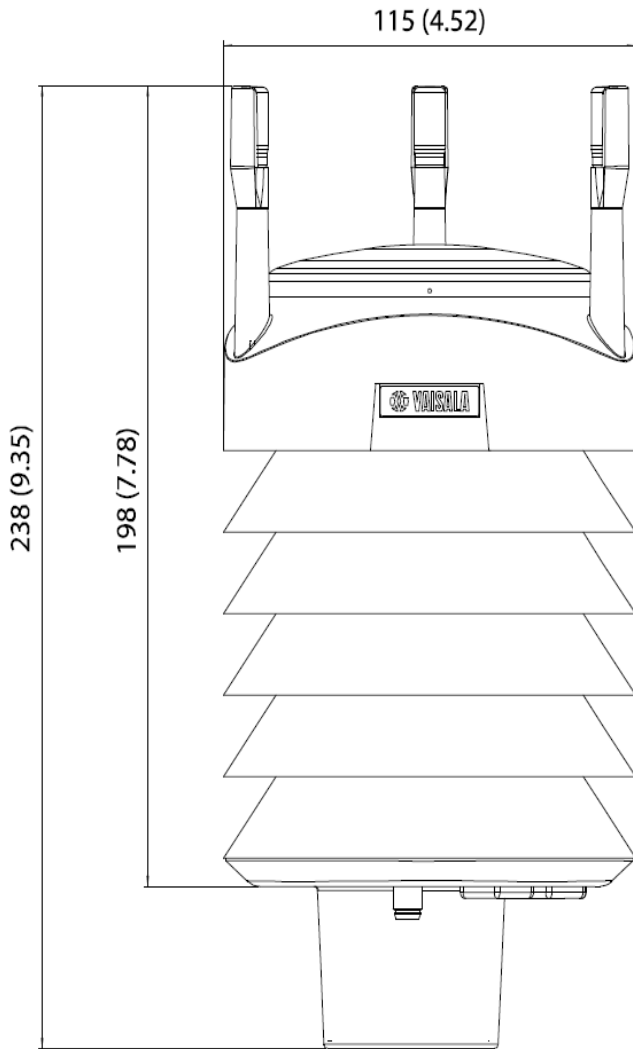

Side view

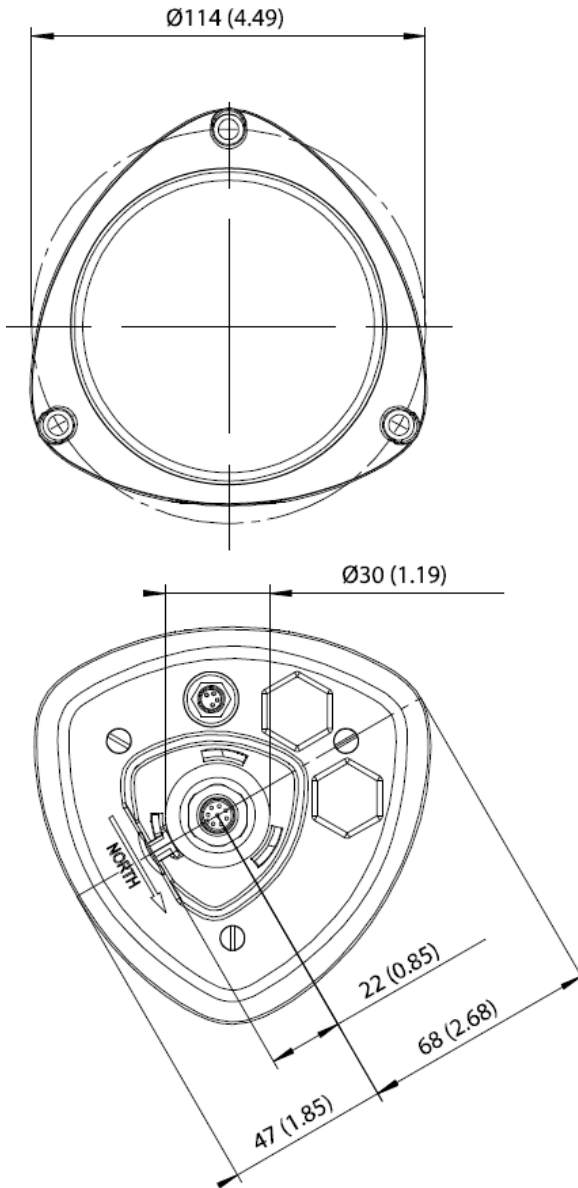

Top and bottom view

Mounting Adapter

To facilitate easy installation and north alignment, the Orion Sensor Transmitter comes standard with a mounting adapter. The mounting adapter is easily connected to the end of the mast and the sensor transmitter simply snaps into it. The north alignment needs to be performed only once.

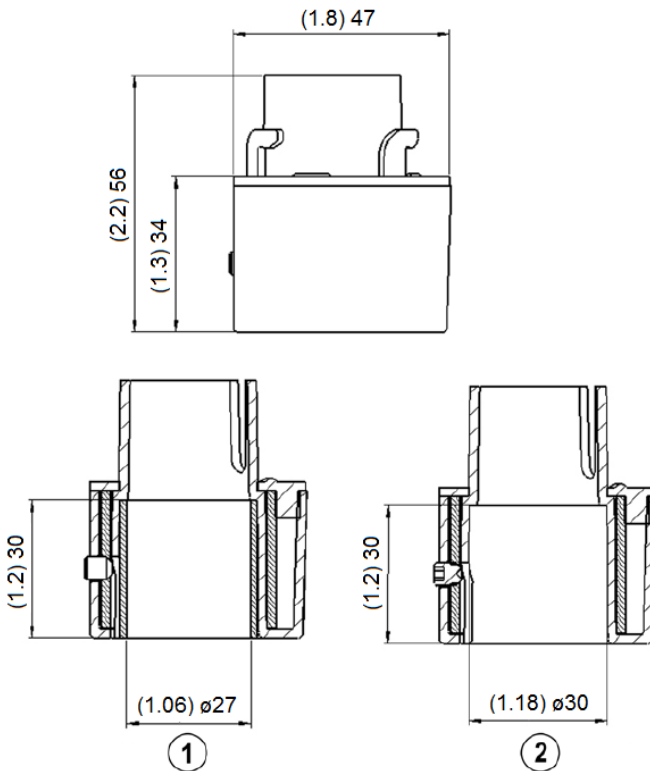
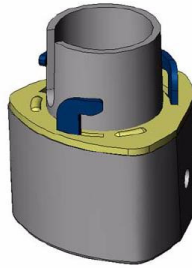

1. Mounting Adapter with adapter sleeve for Ø1.05" mast
2. Mounting Adapter without adapter sleeve for Ø1.18" mast

Internal Terminal Block

The sensor transmitter is shipped with a one (1) foot cable terminated by an 8-pin connector half.

This cable is connected to the sensor transmitter (at the factory) via a terminal block.

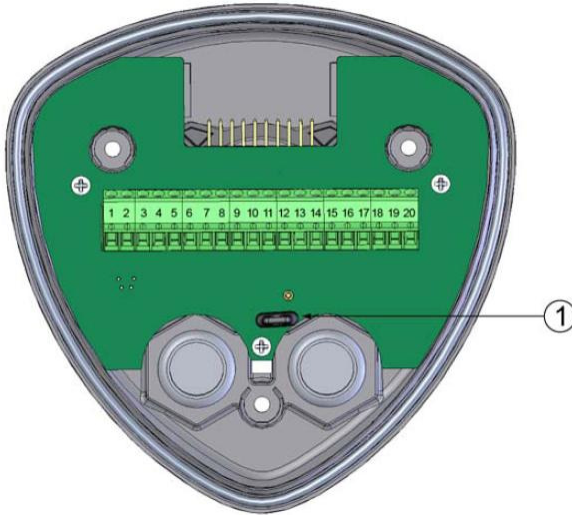

1: Grounding jumper (remove for ship marine applications).

Heating (Optional)

Heating elements located below the precipitation sensor and inside the wind transducers keep the precipitation and wind sensors free from snow and ice. A heating temperature sensor (T_h) beneath the precipitation sensor controls the heating.

Note that (T_h) is measured inside the transmitter, where temperature is much higher than the ambient temperature (T_a).

Three fixed temperature limits, namely +4 °C, 0 °C, and -4 °C (+39 °F, +32 °F, +25 °F) control the heating power as follows:

- When ambient temperature (T_a) falls below +4 °C, heating is enabled.
- Heating keeps $T_h > +4$ °C until $T_a < -1$ °C
- Heating keeps $T_h > 0$ °C until $T_a < -15$ °C

Interface Module

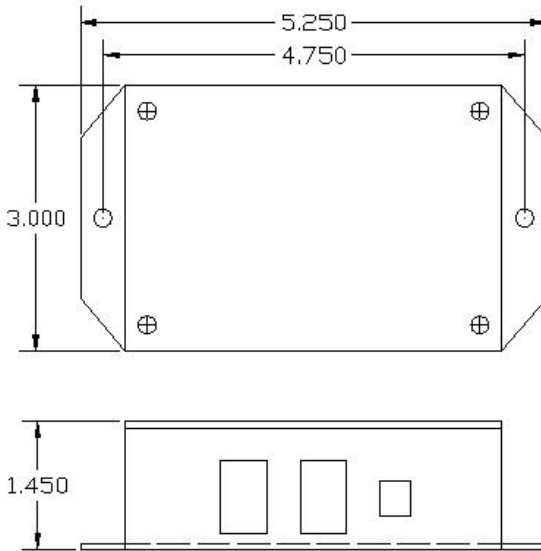

The Interface Module is used to supply power to the sensor transmitter and to provide two RS-232 communication ports. The RS-232 ports can be connected to computers, display consoles, transceivers, and other such devices.

The Interface Module has two LED indicators. The green LED is a power indicator and the red LED is a data indicator. In normal operation, the red LED will flash every second to indicate a data record being transmitted. The green LED will remain solid to indicate power is being supplied to the Orion sensor transmitter.

Surge/Lightning Protector



A nearby lightning strike may induce a high voltage surge which the internal suppressor of your weather instrument may not be able to withstand, causing significant damage to the weather station. Protect your weather station investment with the Surge Protector. This compact transient overvoltage suppressor is designed for weather stations in areas with an elevated risk of lightning strikes such as the top of high buildings, or installations with cable lengths greater than 100 feet.

- Superior 3-stage surge protection
- Tolerates up to 10kA surge currents
- Both differential and common mode protection on each channel
- Filtering against HF and RF noise
- Two power channels and two data channels
- Environmental protection class IP66

Part Number: 8355

Includes adjustable mounting kit

WeatherMaster™ Software (Optional)

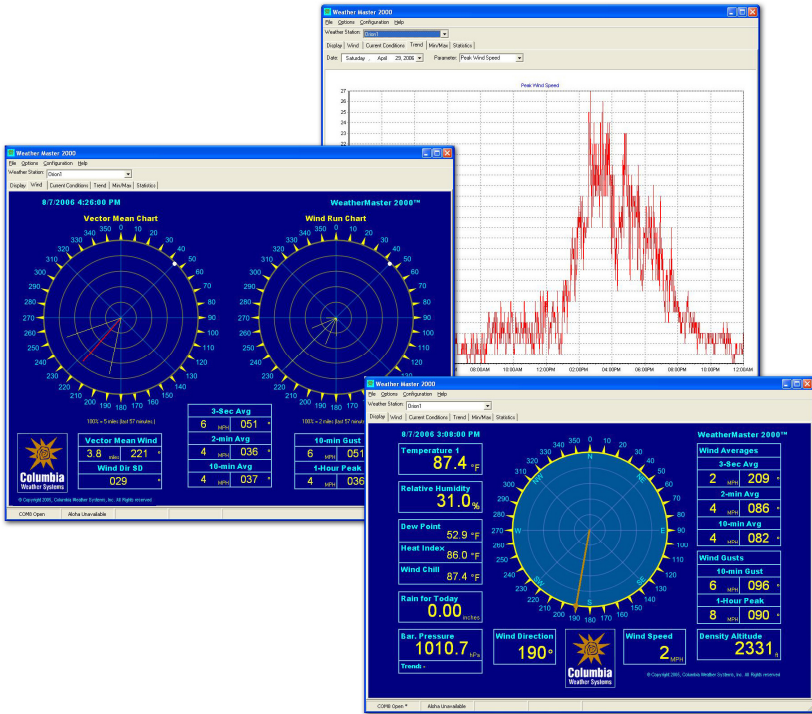

WeatherMaster is professional grade weather monitoring software. This software package is designed for specialized markets that require robust weather calculations, interoperability with computer models, and data interfaces to other industrial systems. WeatherMaster utilizes Microsoft Access database for easy data access and manipulation.

Please refer to the WeatherMaster user manual for installation and operation procedures.

Weather Display Console (Optional)



Displays weather information • Designed to be viewed clearly from a distance • Industrial grade WVGA touchscreen.

Seven-inch, TFT color LCD panel with 800 x 480 pixel resolution.

Performs computations for wind chill, heat index and other calculated parameters • 200MHz ARM9 CPU

Serial or Ethernet connection: Connects directly to weather station with serial port or connects to a Weather MicroServer over a network utilizing an existing Ethernet infrastructure -- no extra wiring. The MicroServer configuration also allows for data from one weather station to be monitored from multiple display consoles at various locations.

Screens can be factory-customized to meet specialized market and industry requirements.

The Weather Display is also available in a 19" rack-mount chassis and a panel-mount configuration.

Please refer to the Weather Display Console user manual for more information.

Weather MicroServer (Optional)

The Weather MicroServer uses a small computer board that runs an embedded Linux operating system.

The MicroServer has 32MB flash memory for operation and 8 GB SD card for data logging.

The Orion transmitter connects to the MicroServer via COM1.

The MicroServer has two RS-232 COM ports and an Ethernet port.

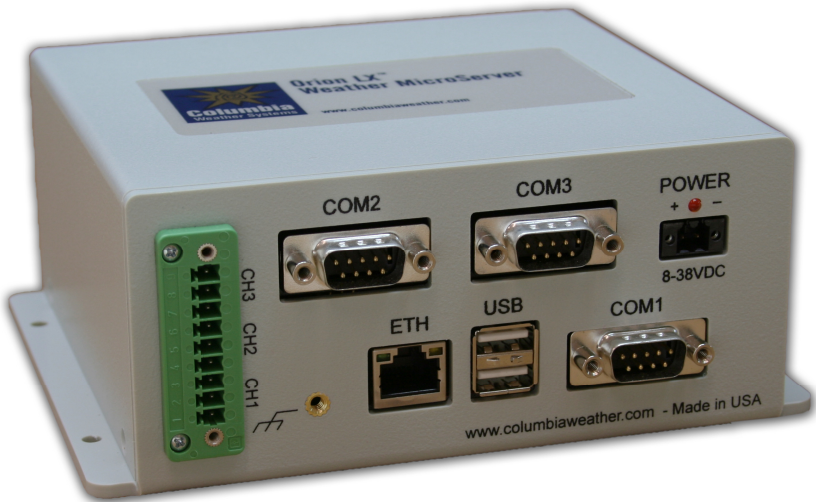

The MicroServer offers the following:

- XML Weather Data
- FTP weather data in XML or CSV format
- Modbus/TCP, Modbus RTU (Serial RS-485)
- SNMP interface, DNP3 interface, BACnet interface
- Weather Underground & Anything Weather interface
- CWOP interface
- Years' worth of data logging at 1-minute interval
- Interface to optional visibility and solar radiation sensors

SECTION 3: FIXED MOUNT INSTALLATION

Fixed Mount System Configurations

The Fixed Mount Orion Weather Station can be installed in multiple configurations depending on communication options, power availability and viewing options.

Cabled System:

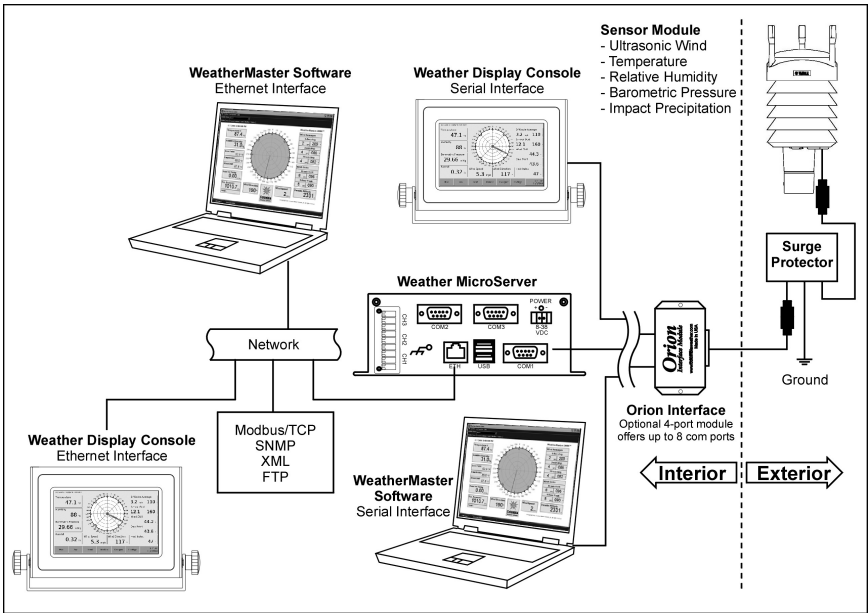

Wireless System with Weatherproof Enclosure:

Following is an example of a wireless configuration.

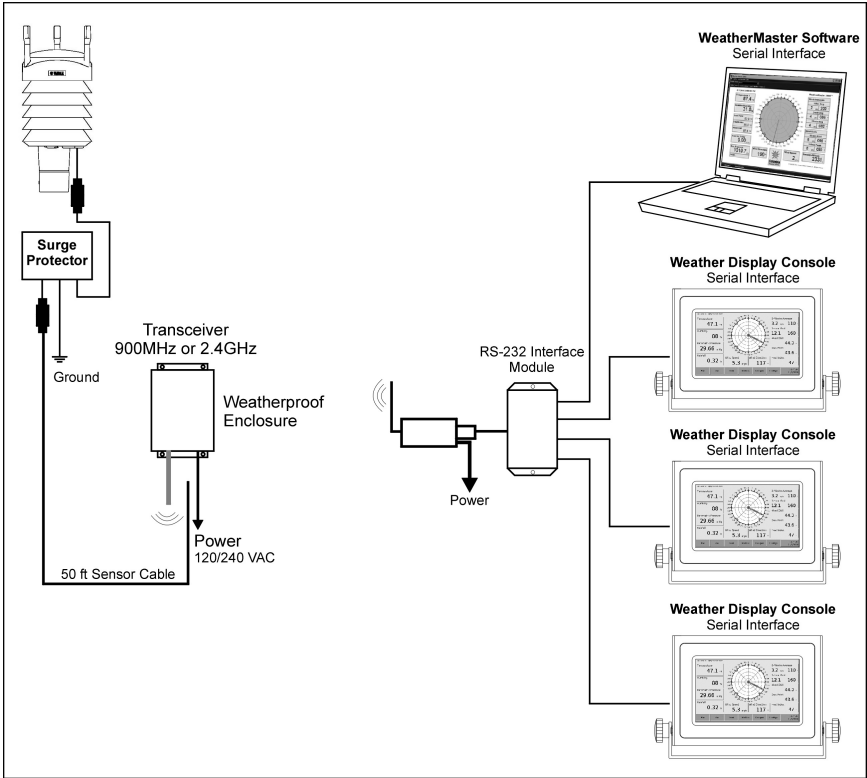

Installation Overview

Unpacking the System

Installing the Mast

Installing the Sensor Transmitter

Installing the Surge Arrestor

Connecting the Sensor Transmitter to the Interface Module

Connecting to MicroServer, Weather Display and Computer

Unpacking the Unit

The sensor transmitter comes in a custom shipping container. Be careful when removing the device.

CAUTION: Beware of damaging any of the wind transducers located at the top of the three antennas. Dropping the device can break or damage the transducers. If the antenna bends or twists, the re-aligning can be difficult or impossible.

Unpack the Orion weather station and verify that all parts are included.

1. Standard system includes:

- Orion Sensor Transmitter
- 50 ft sensor cable + additional cable length if ordered
- Interface Module
- (2) 3-position terminal blocks
- Interface module power supply
- User Manual
- 6-foot RS-232 cable + additional cable length if ordered

2. Weather Display Console (**Optional**)

- Display Console
- Power supply
- 6-foot RS-232 cable + additional cable length if ordered
- User manual

3. WeatherMaster software and user manual (**Optional**)

4. Weather MicroServer (**Optional**)

- MicroServer

- Power supply
- 7-foot Ethernet cable
- User manual

Inspect all system components for obvious shipping damage (Refer to “Important Notice: Shipping Damage” in case of damage).

NOTE: Save the shipping carton and packing material in case the unit needs to be returned to the factory. If the system does not operate or calibrate properly, see **Maintenance** and **Troubleshooting** sections, for further instructions.

Installing the Mast

There are three acceptable methods for mounting the mast to a roof or building structure: Sloped roof mounting, flat roof mounting or wall mounting. See **Optional Sensor Mounting Hardware** for more information.

Location

Do not attach the sensor transmitter to a radio transmitting mast or tower.

Select a mounting location that will allow the sensor cable to be routed away from other data cables to avoid interference. Do not mount sensors close to power lines. For normal roof mounting, the recommended minimum distance from power lines is 25 ft. (8 m). Use extreme caution when working close to power lines.

Mounting Method

Choose the appropriate mounting method for the installation and obtain any necessary mounting hardware. Refer to Optional Sensor Mounting Hardware section for information on optional sensor mounting hardware and accessories which are available from the factory.

If the mounting hardware is not obtained from the factory, be certain to use metal parts which are plated or galvanized to assure maximum longevity.

Secure the mast to the roof, using guy wires with sufficient tensile strength or to building wall using a wall-mount hardware kit.

Routing Cable

Use plastic tie wraps to secure the cable to mast, particularly at the mast base. Tighten the tie wraps securely and clip off any excess length with a wire cutter tool.

Once the Orion sensor transmitter has been placed, route the cable back to the Interface Module or weatherproof enclosure.

CAUTION: There may be electric wires in the wall. When routing cable through walls, we recommend that you shut off the electricity in the room(s) where you are drilling.

Any mast or tower should always be properly earth grounded to minimize electrical storm damage. The use of a properly grounded metal mast or tower, however, does not insure protection from electrostatic discharge.

These items could become electrically charged resulting in damage to the sensors and/or console. This could damage the system in the event of an electrical storm.

Note: If the standard 50 ft. cable provided with the sensor transmitter is not long enough, it may be extended by splicing on an appropriate length of 22-gauge, stranded, seven conductor shielded cable with the same color code. When cutting and splicing, insure good contacts, proper color coding of the terminal leads, and a good seal. (A good solder splice, and water proof insulation are essential; merely twisting the respective wires together is not adequate.) Additional cable (Part No. 81547) is available from the factory.

Installing the Orion Sensor Transmitter

Site Selection:

Finding a suitable site for the sensor transmitter is important in obtaining representative ambient measurements. The site should represent the general area of interest.

The sensor transmitter should be installed in a location that is free from turbulence caused by nearby objects, such as trees or buildings.

WARNING: To protect personnel (and the device), a lightning rod should be installed with the tip at least 40 inches (one meter) above the sensor transmitter. The rod must be properly grounded, compliant with all local applicable safety regulations.

Installing the Mounting Adapter

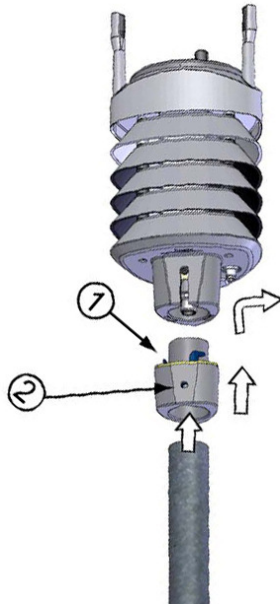

1. Insert the mounting adapter ① in the transmitter bottom side as shown in the diagram above.
2. Turn the adapter firmly until you feel that it has snapped into the locked position.
3. Align the transmitter in such a way that the arrow (at the bottom of the transmitter) points to north (see North Alignment).
4. Tighten the fixing screw ② to fix the adapter firmly to the mast.

North Alignment

To help the alignment, there is an arrow and text **North** on the bottom of the transmitter. The transmitter should be aligned in such a way that this arrow points to the north.

Wind direction can be referenced to true north, which uses the earth's geographic meridians, or magnetic north, which is read with a magnetic compass. The magnetic declination is the difference in degrees between the true north and magnetic north.

Compass Alignment

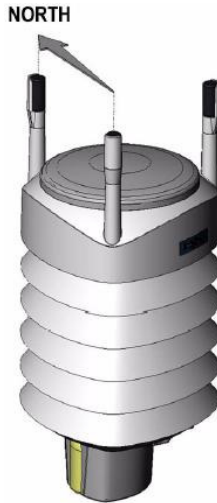

1. If the sensor transmitter is already mounted, loosen the fixing screw on the mounting adapter.
2. Use a compass to determine that the transducer heads are exactly in line with the compass and that the arrow on the bottom of the transmitter points to north.
3. Tighten the fixing screw on the mounting adapter when done.

Once the sensor transmitter is aligned to north, the transmitter can be removed from the mounting adapter without losing the north orientation.

Installing the Surge Arrestor

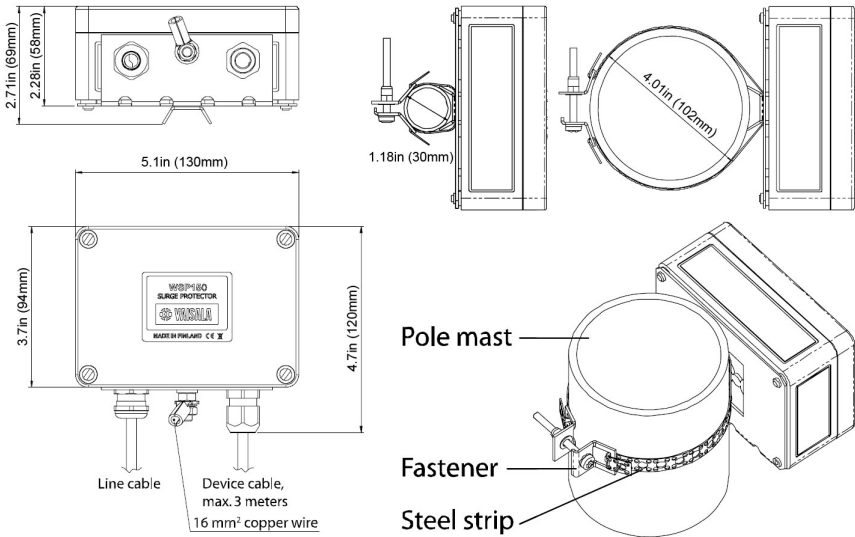

1. Attach the unit to the mast close to the weather sensor with the adjustable mounting clamp, see figure above.
2. Slide the steel strip beneath the latch on the back of the enclosure.
3. Wrap the steel strip around the pole mast. You may shorten the strip to a suitable length.
4. Loosen the fastener by backing up the screw half way.
5. Attach the steel strip ends to the fastener by latching the fastener to a hole on the strip and folding it over.
6. Tighten the fastener's screw in order to secure the unit to the pole.
7. Ground the unit using an AWG 6 (16 mm²) copper wire.

Connecting the Sensor Transmitter to the Interface Module

Using a #1 Straight Slot screwdriver, attach the wires from the end of the sensor cable to the terminal block screws on the Interface Module as follows:

Terminal Number	Signal	Color
1	+12 V	RED & Brown*
2	Ground	White, Bare & Blue*
3	No Connection	
4	Signal Ground	Green
5	RX	Black
6	TX	Orange

* For optional heater

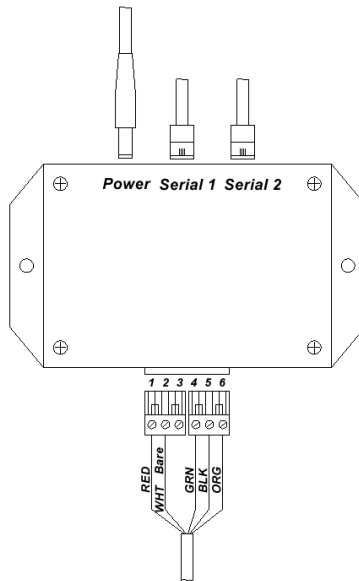

For heated sensor transmitters, connect the brown wire along with the red wire to position 1 and connect the blue wire along with the white and bare wires to terminal 2.

Optional Sensor Mounting Hardware

Telescoping Tripod and Tiedown Kit

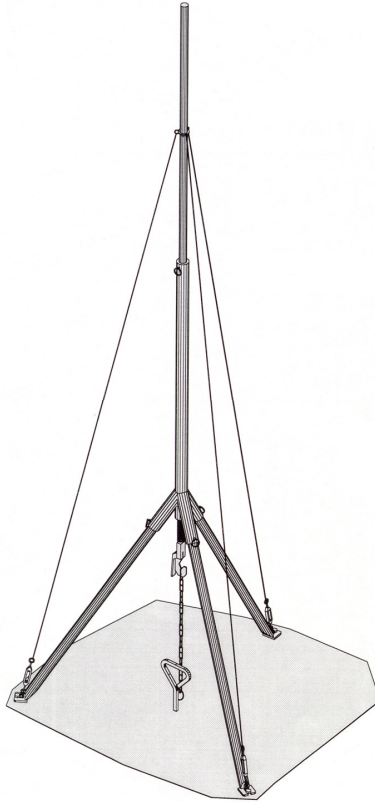

The tripod is designed to provide up to 10 feet of stable, secure support for your meteorological sensors. Constructed from welded aluminum and powder coated for appearance and longevity, the 15-pound tripod can easily support up to 60 pounds of equipment. An optional tie-down kit allows for additional security in high-wind areas.

To install, insert the legs into the main body and secure with stainless steel retainer pins. Extend the mast to the desired height and insert another retainer pin. Install the guy wires to complete the set-up.

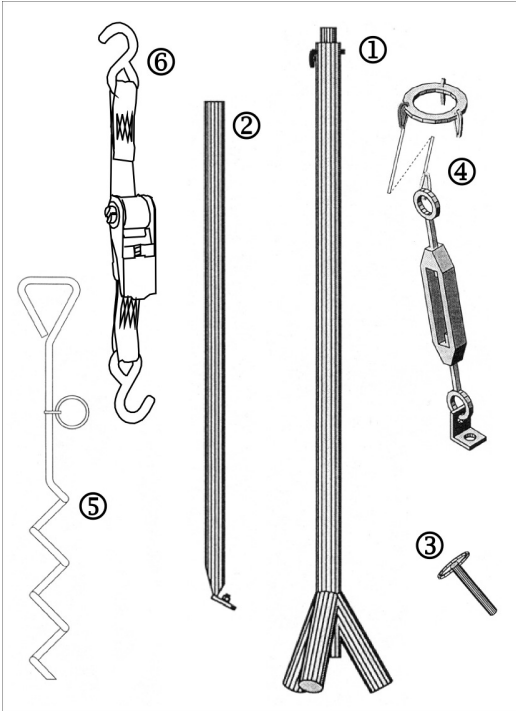
Tripod Parts List:

Description	Ref.	Qty.
Body/Mast Assembly	1	1
Legs	2	3
Retainer Pins	3	4
Guy Wire Ring with 3 Wires and Turnbuckles	4	1
Anchor Screw with Chain	5	1
Clamp with Strap	6	1

Specifications

Capacity: Supports up to 60 lbs.

Shipping Weight: 17 lbs

Shipping Box Dimensions: 71" x 9" x 9"

Tripod and Tiedown Kit Part Number: 88019

Sensor Mast

10-foot steel mast available for use with Roof Mount Hardware Kit (Part No. 88002) or Wall Mount Kit (Part No.88003).

Roof Mounting

The Roof Mount Kit (Part No. 88002) is suitable for both a slanted and flat roof installation. The figure and table below illustrates and describes the individual parts.

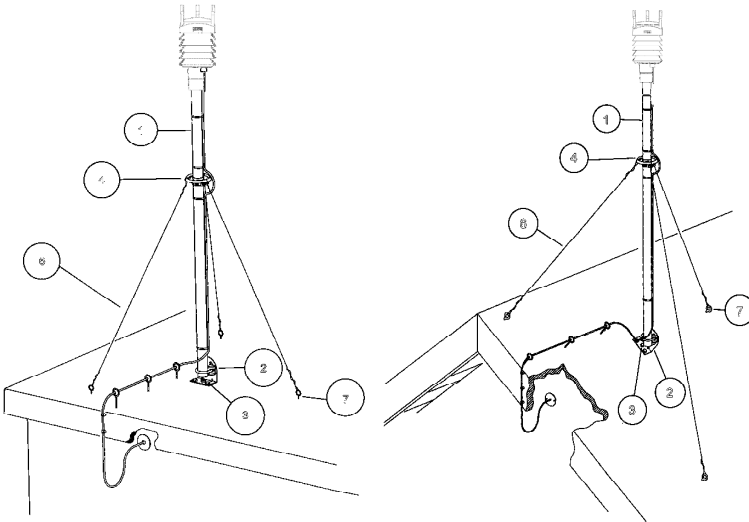

Description	Ref.	Qty.	Part No.
Steel mast, 10 ft.	1	1	88005
Universal Mast Anchor	2	1	88010
Lag Screw, Roof Mast Mount 1/4" x 2 1/4" (for comp. roofs)	3	4	88030
Guy Wire Clamp, 1/8"	4	1	88070
Steel Guy Wire, Galvanized	6	50ft.	88080
Eye Bolt Wood Screws, 1/4" x 3"	7	4	88090
Turnbuckles, 6" open x 4" closed (not shown)	3		88100

Wall Mounting

The figure and table below illustrates and describes the individual parts in the Wall Mounting Kit (Part No. 88003). Individual parts are also available.

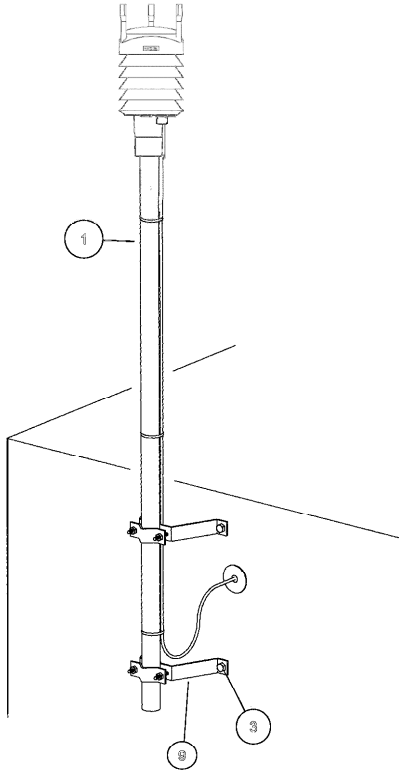

Description	Ref.	Qty.	Part No.
Mast, 10 ft.	1	1	88005
Lag Screw	3	4	88030
4" Wall Mount Bracket	9	2	88120

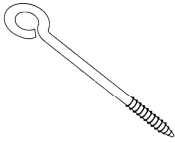

EYE BOLT SCREW

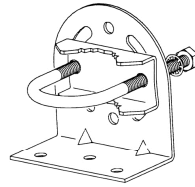

UNIVERSAL MAST ANCHOR

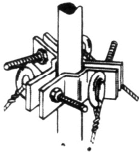

GUY WIRE CLAMP

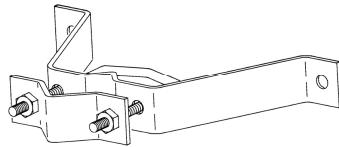

4" WALL MOUNT BRACKET

SECTION 4: VEHICLE MOUNT INSTALLATION

The Orion Weather Station can be configured for a vehicle mount installation for mobile applications.

Vehicle Mount System Configurations

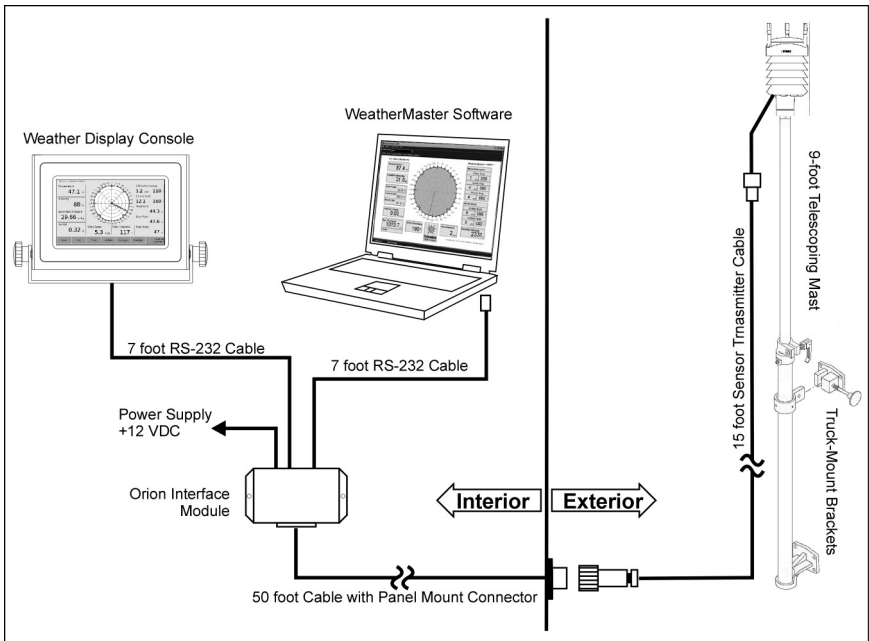

Installation Overview

Unpacking the Unit

Installing the telescoping mast and truck-mount brackets

Installing the vehicle mount connector and routing cable

Installing the Interface Module

Installing and connecting the Weather Display Console and Computer Software

Installing the Orion sensor transmitter and Quick-North Orientation

Unpacking the Unit

The sensor transmitter comes in a custom shipping container. Be careful when removing the device.

CAUTION: Beware of damaging any of the wind transducers located at the top of the three antennas. Dropping the device can break or damage the transducers. If any the antenna bends, twists re-aligning the sensor can be difficult or impossible.

Unpack the Orion weather station and verify that all parts are included.

1. Standard system includes:

- Orion Sensor Transmitter
- 15 ft external sensor cable and male sensor connector (plus additional cable lengths, if ordered)
- 50 ft internal cable with vehicle mount female sensor connector (plus additional cable lengths, if ordered) and all-weather connector cap
- Interface Module
- (2) 3-positon terminal block connectors
- Interface module power supply
- User Manual
- 6-foot RS-232 cable (plus additional cable lengths, if ordered)
- 9 ft telescoping mast with vehicle-mount brackets
- Mast extension sleeve adapter

2. Weather Display Console (**Optional**)

- Display Console
- Power supply
- 6-foot RS-232 cable (plus additional cable lengths, if ordered)
- User Manual

3. WeatherMaster Software, with User Manual (**Optional**)

Inspect all system components for obvious shipping damage (Refer to “Important Notice: Shipping Damage” in case of damage).

Save the shipping carton and packing material in case the unit needs to be returned to the factory. If the system does not operate or calibrate

properly, see **Maintenance** and **Troubleshooting** sections, for further instructions.

Installing the telescoping mast and vehicle-mount brackets

1. Select a location on the vehicle where the Orion sensor mast will be installed.
2. Three mounting brackets are included with the mast. The mounting base plate and a spring-loaded securing mounting bracket will be permanently mounted to the vehicle for quick and easy set up. The third bracket is attached to the mast and mates with a slot on the spring-loaded mounting bracket. This bracket may be loosened and re-positioned on the mast to fit the installation scheme and mounting bracket positioning. A spacer for the spring-loaded bracket is provided to insure that the mast is 90° vertical.
3. Ensure the vehicle-mount sensor connector is in close proximity to the mast's mounting bracket location (refer to the vehicle-mount sensor connector section below). Mark and drill the appropriate mounting bracket holes. Be sure to allow for sufficient structural backing, to adequately support the mast and sensor.
4. External sensor cabling is intended to hang freely along the side of the mast. This assures the mast's easy extension and retraction without pinching, crimping, or cutting the sensor cable. Users may tie-wrap the cable to the lower portion of the mast. The external sensor cable has a male connector that couples to the vehicle-mount female connector on the side of the vehicle.
5. To extend the mast, locate the large textured locking ring at the top of the nested mast. This ring loosens and tightens the mast extension. A counter-clockwise rotation loosens the ring and allows the mast to be fully extended. Clockwise ring rotation tightens the extension in place.

Installing the telescoping mast and vehicle-mount brackets



Spacer
017-0010-006

Spring Loaded
Bracket
017-0010-003

Ring Collar
Bracket
017-0010-002

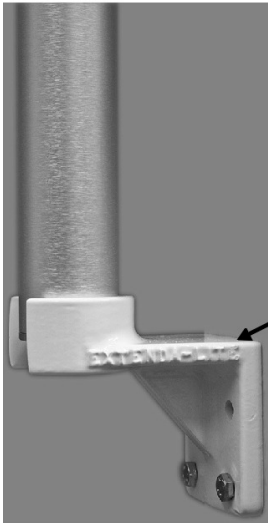

Base Plate
Bracket
017-0010-004



Fully Extended
104.5 inches

Collapsed
60.00 inches

Pull-up pole
017-0010-001

Mast shown in collapsed position

Installing vehicle mount sensor connector and routing cable

1. To install the female vehicle-mount sensor connector, drill a $\frac{3}{4}$ " hole in close proximity to the sensor mast mounting bracket installation. A recommended location is near the mast's lower base bracket.
2. Drill four small pilot holes for the mounting screws.
3. Run 50-ft cable through the hole and route to the Orion Interface Module location.
4. Connect the cable to the 3-position connectors, as listed in the chart below.
5. Affix the connector with mounting screws on the external side of the vehicle and ensure the associated all-weather connector cap is securely attached.

Installing the Interface Module

Using a #1 Straight Slot screwdriver, attach the wires from the end of the sensor cable to the terminal block screws on the Interface Module as follows:

Terminal Number	Signal	Color
1	+12 V	RED
2	Ground	White and Bare
3	No Connection	
4	Signal Ground	Green
5	RX	Black
6	TX	Orange

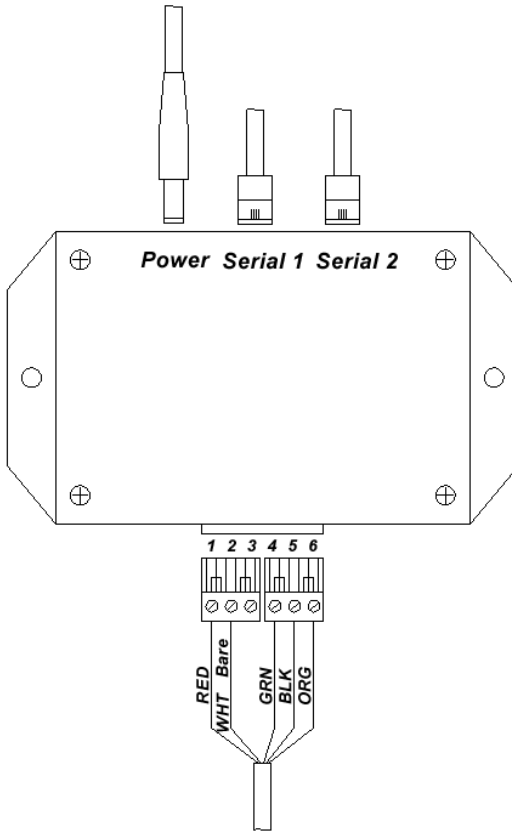

Connecting the Weather Display Console and Computer

Connect the Weather Display Console to the Interface Module using the RJ-11 cable. The Display Console can be connected to either serial port 1 or 2

Connect the Interface Module to the computer using the RJ-11 and DB-9 connector (RS-232 Interface). The computer can be connected to either serial port 1 or 2. On the computer end, the DB-9 connector is plugged into the computer serial port (normally COM port 1). If the computer does not have a serial port, then a USB to Serial Port converter will be needed.

Installing the sensor transmitter and North Orientation

Installing the Mounting Adapter

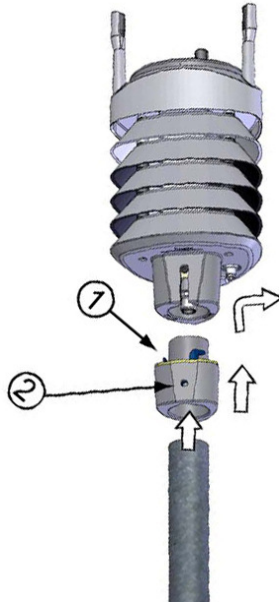

1. Insert the telescoping mast sleeve adapter by screwing it into the threaded portion atop the mast extension.
2. Insert the mounting adapter ① in the transmitter lower side as shown in the diagram above.
3. Turn the adapter firmly until you feel that it has snapped into the locked position.
4. Align the transmitter in such a way that the arrow (on the underside of the transmitter) points to the front of the vehicle (see North Alignment).
5. Tighten the Allen screw ② to firmly and permanently fix the adapter firmly to the sleeve adapter.

North Alignment

North Orientation: Locate the alignment arrow and text **North** on the underside of the transmitter. With the mast mounted on the vehicle, extend the mast to its fullest extension. Before tightening the mast into place, use a field compass to orient the transmitter in such a manner that the alignment arrow points to Magnetic North. Rotate the mast extension until the sensor is properly oriented. Tighten the locking nut.

Wind direction can refer to either **Magnetic North**, which is read with a magnetic compass, or **True North**, which uses the earth's geographic meridians. The magnetic declination is the difference in degrees between the true north and magnetic north.

Magnetic Declination for the U.S.

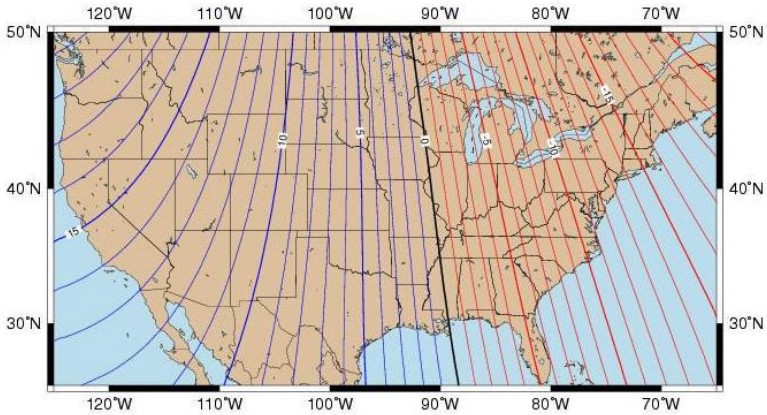

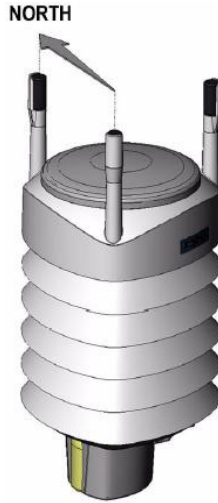

1. If the sensor transmitter is already mounted, loosen the fixing screw on the mounting adapter.
2. Use a compass to determine that the transducer heads are exactly in line with the compass and that the arrow on the bottom of the transmitter points to north.
3. Tighten the fixing screw on the mounting adapter when done.

Once the sensor transmitter is aligned to north, the transmitter can be removed from the mounting adapter without losing the north orientation.

SECTION 5: ORION NOMAD PORTABLE INSTALLATION

The Orion Weather Station can be configured as a portable system for rapid deployment applications.

Orion Nomad System Configurations

Orion Nomad with WeatherMaster Software:

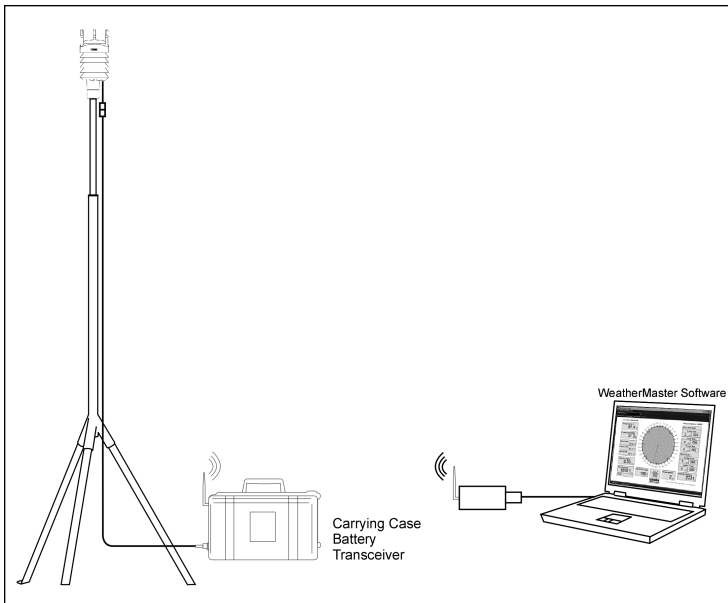

Orion Nomad with Weather Display Console:

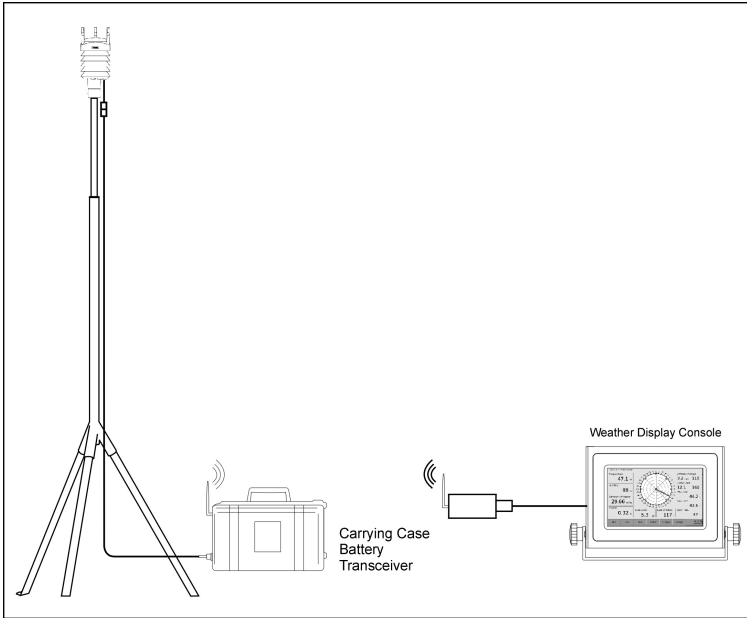

Orion Nomad with WeatherMaster Software and Weather Display Console:

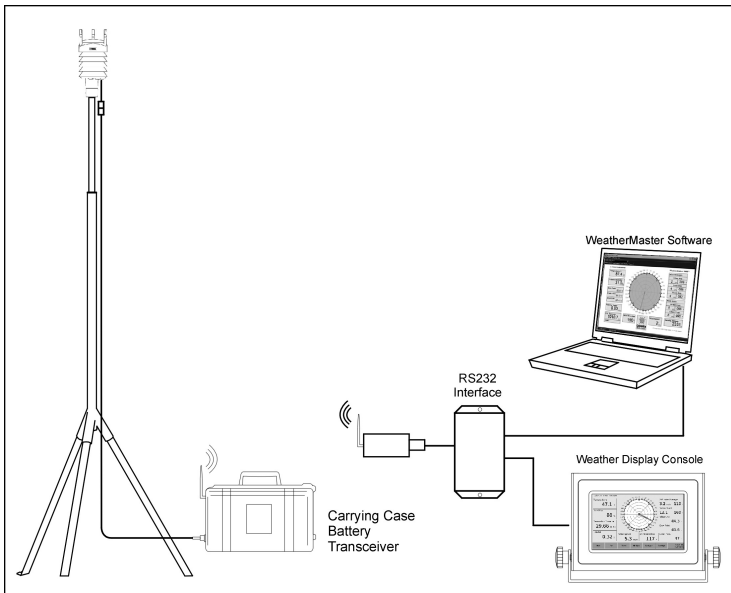

Orion Nomad with Weather MicroServer:

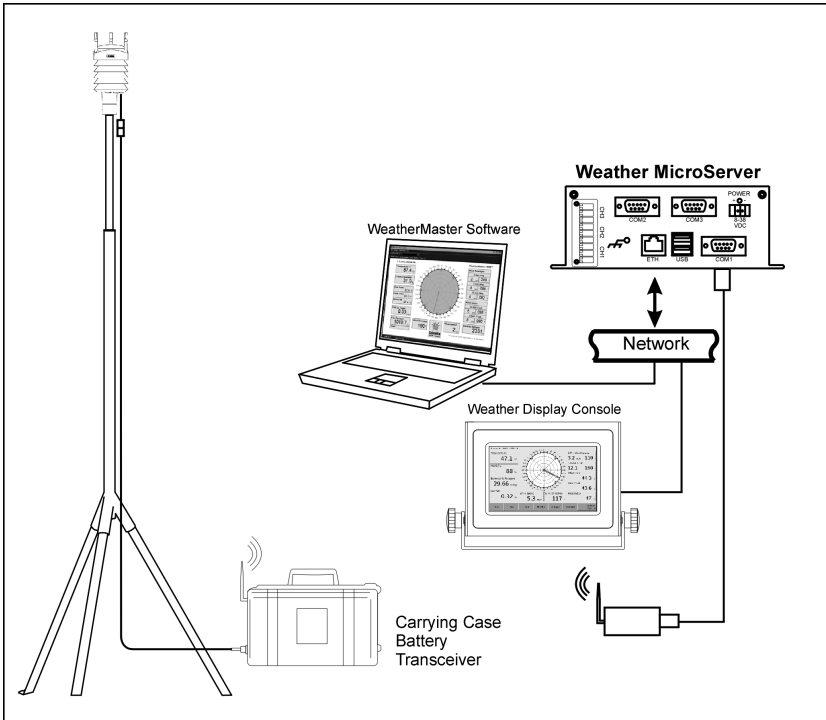

Unpacking the Unit

CAUTION: Beware of damaging any of the wind transducers located at the top of the three antennas. Dropping the device can break or damage the transducers. If the antenna bends or twists, the re-aligning can be difficult or impossible.

Standard system includes:

1. System Carrying Case
 - Orion Nomad Sensor Transmitter
 - 15 ft sensor cable
 - 2.4 GHz Transceiver and antenna
 - (2) 12 volts Batteries
 - Battery Charger
 - User Manual
2. Tripod
 - Guy wire and collar
 - Tie-down kit
 - Canvas tripod bag

3. Receiving Transceiver
 - 2.4 GHz Transceiver and antenna
 - 6-foot RS-232 Transceiver cable
 - Orion Interface Module (**Optional**)
4. Weather Display Console (**Optional**)
 - Display console
 - Power supply
 - 6-foot RS-232 cable
 - User manual
5. WeatherMaster software (**Optional**)
 - Software CD
 - User manual
 - 6-foot computer cable
6. Weather MicroServer (**Optional**)
 - MicroServer
 - User manual
 - 7-foot Ethernet cable
 - Power supply

Inspect all system components for obvious shipping damage (Refer to “Important Notice: Shipping Damage” in case of damage).

Save the shipping carton and packing material in case the unit needs to be returned to the factory.

Orion Carrying Case



The Orion Nomad carrying case stores the sensor head, batteries, transceivers and other accessories. It serves as a weatherproof enclosure with a wiring harness, antenna, and connection to the sensor head for power and communication via the wireless transceiver.

Telescoping Tripod and Tiedown Kit

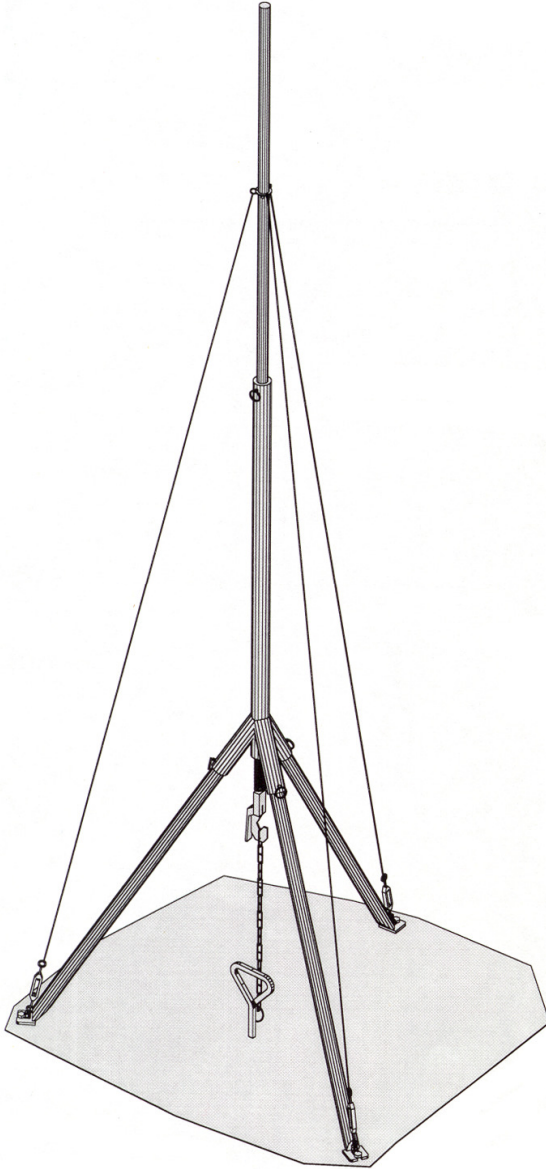

The tripod is designed to provide up to 10 feet of stable, secure support for your meteorological sensors.

Constructed from welded aluminum and powder coated for appearance and longevity, the 15-pound tripod can easily support up to 60 pounds of

equipment. An optional tie-down kit allows for additional security in high-wind areas.

To install, insert the legs into the main body secure with stainless steel retainer pins. Extend the mast to the desired height and insert another retainer pin. Install the guy wires to complete the set-up.

Tripod Parts List:

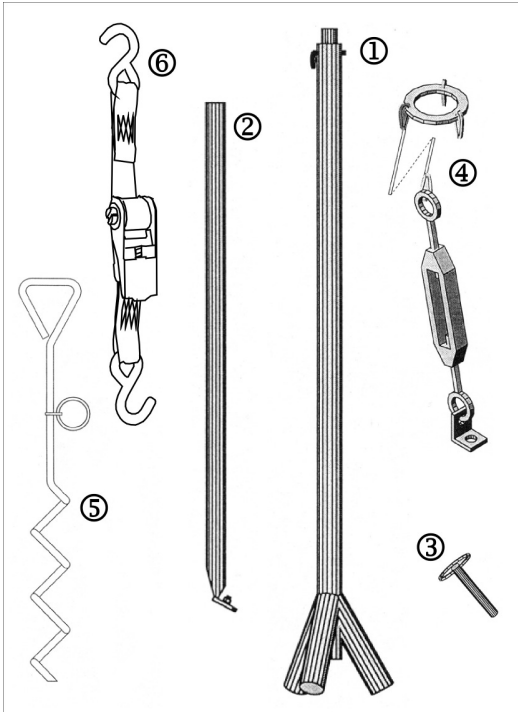

Description	Ref.	Qty.
Body/Mast Assembly	1	1
Legs	2	3
Retainer Pins	3	4
Guy Wire Ring with 3 Wires and Turnbuckles	4	1
Anchor Screw with Chain	5	1
Clamp with Strap	6	1

Specifications

Capacity: Supports up to 60 lbs.

Shipping Weight: 17 lbs

Shipping Box Dimensions: 71" x 9" x 9"

Tripod and Tiedown Kit Catalog Number: 88019

RS-232 Interface Module

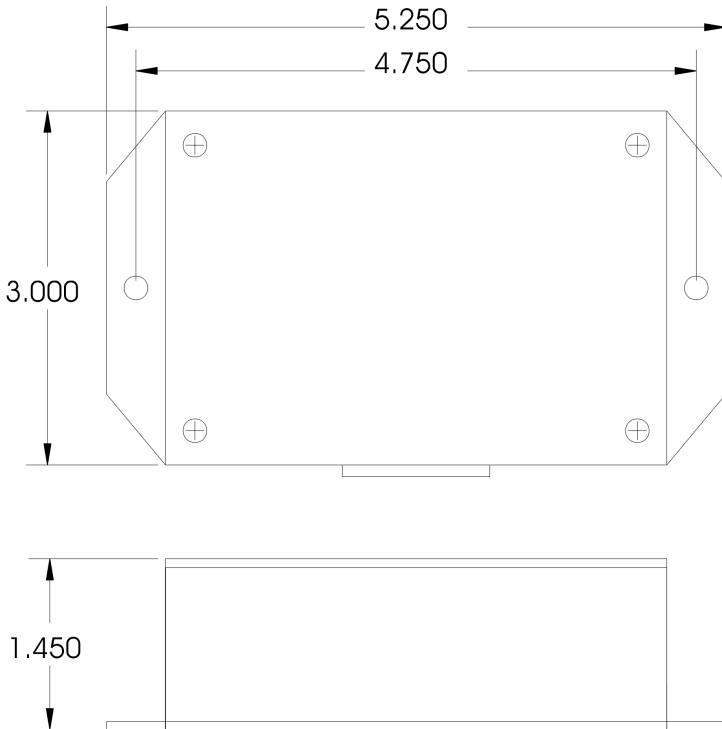

The RS-232 Interface Module connects up to four devices to the wireless transceiver, such as computers, display consoles and other such devices.

Installing the Mounting Adapter

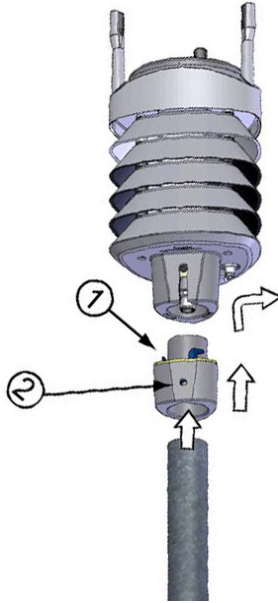

1. Insert the mounting adapter ① in the transmitter lower side as shown in the diagram above.
2. Turn the adapter firmly until you feel that it has snapped into the locked position.
3. Align the transmitter in such a way that the arrow (at the bottom of the transmitter) points to north (see North Alignment).
4. Tighten the fixing screw ② to fix the adapter firmly to the mast.

Set Up Instructions

Site Selection:

1. Upon arrival at the deployment site, determine a suitable location where the Orion Nomad mast may be set up away from physical obstructions and heavy foot traffic. Because of Orion's wireless transceivers, the telescoping tripod and sensors may be removed as far as 3-miles (Line of Sight - LOS) away from where the weather data is viewed.
2. Site location should be away from trees, buildings or other obstructions that will alter accurate wind direction and speed-readings.

3. Screw the grounding/tie-down auger into the ground at the center of the placement until the auger portion is adequately secured.
4. If the site selection is on blacktop/pavement, use a 6" nail spike or Rebar driven into the surface at a 45° angle. This sufficiently secures the mast during operations.

Mast Set Up and Sensor Alignment:

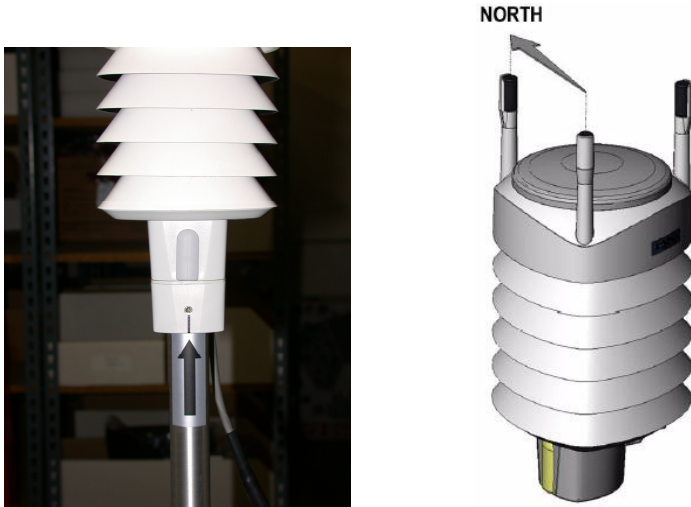

Figure 1. Tripod North Orientation Alignment

1. Remove tripod components from the bag. Stand the tripod up (without legs) so the sensor head may be attached to the mast.
2. The mounting bracket/alignment adapter should be permanently secured to the mast. **NOTE: THE ALIGNMENT ARROW ON THE MAST AND THE BLACK TICK-MARK ON THE ALIGNMENT ADAPTER SHOULD ALWAYS BE ALIGNED TO ENSURE PROPER NORTH ORIENTATION.**
3. Attach the Sensor Head to the alignment adapter by aligning the female slots on the Sensor Head to the male teeth on the alignment adapter. **NOTE: THE RUBBER SLOT COVER ON THE SENSOR HEAD SHOULD ALIGN WITH THE ADAPTER TICK-MARK AND MAST MARKING ARROW.**
4. Attach sensor cable by connecting the 8-pin waterproof male connector/sensor cable to the one-foot female sensor pig-tail waterproof connector.
5. Holding the tripod vertical, place tripod legs in their respective slots, one leg at a time. Once the first leg is in, balance the tripod until the other legs are inserted and the tripod is free standing.

6. With all legs in place, insert the leg locking pins. The tripod may now be picked up and moved around for final placement and North Orientation over the grounding stake.
7. Secure the tripod to the grounding stake using the spring-loaded chain. Ensure the chain is tight enough to keep the tripod in-place during high winds, but not so tight to fully extend the spring.
8. Using the attached compass, locate magnetic North. Point the opposite (front) tripod leg and align it North (magnetic North). Because the wind sensor and alignment arrows have already been aligned, the entire mast and wind sensor is now configured to magnetic North. See Figure 2.

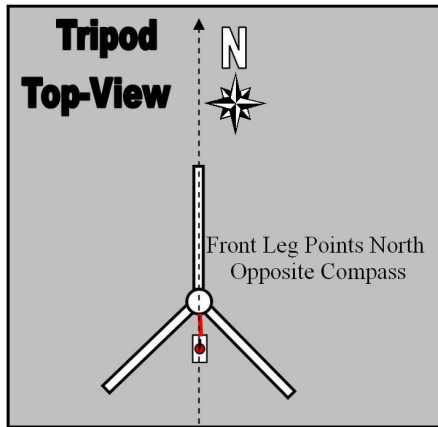

Figure 2. Tripod North Orientation Diagram

9. Extend the mast to its fullest height and insert the locking pin. **NOTE: MAST POSITION ARROWS MUST BE PROPERLY ALIGNED TO ENSURE NORTH ORIENTATION.**
10. If the guy wire kit is used, remove the alignment adapter prior to mast set up and slide the guy wire ring collar onto the mast extension, then reinstall the alignment adapter. Anchor the end of each guy wire to the corresponding tripod foot using the wing nuts. Extend the mast fully and adjust the guy wires using the turnbuckles to tighten the guy wires evenly.

Transportation Case and Sensor Plug-In

1. Place the Orion Nomad transportation case at the foot of the tripod.
2. Attach the 8-inch wireless antenna to the antenna cable on the outside of the case.
3. Plug the 8-pin Female Sensor Cable to the 8-pin male connector on the outside of the case.
4. Ensure the red/black power cord connectors are connected to their respective battery terminals inside the case.
5. Latch and Seal the case to the internal components from the weather elements.

Battery Power System

1. The Orion Nomad comes with a Battery Power System that consists of two 12VDC, 7.5AH batteries and a 12-Volt battery charger. One battery will continuously operate the Orion Nomad for approximately 60 hours. One battery is intended to be charging while the other is in operation.
2. Swap batteries, as necessary to continue weather station operations.

Operation

Once Mast is set up, with the Sensor Head attached & aligned, plug the red/black power terminals to the corresponding battery terminals. The Orion will automatically sense and transmit weather data via wireless transceiver.

1. Transceiver Power/Connectivity/Transmission:
 - a) Check for the red power light
 - b) Check for the steady green connectivity light
 - c) Check for the one-second green pulsing/blinking transmission light
2. Once the transceiver lights are all operational, data is being transmitted. If the green transmission light is not blinking once per second, data is not being transmitted. Re-check the RS-232, power, and antenna connections.

Monitoring

The data transmitted from the remote sensor can be monitored using the Weather Display console, computer weather software, and/or Weather MicroServer.

Connect the wireless transceiver to the appropriate device. Please refer to the system diagrams in the beginning of this chapter.

SECTION 6: OPERATION

Orion Sensor Data Output Definition

Wind data is transmitted every second, PTU data is transmitted every 15 seconds, and Precipitation data is transmitted every 0.01 inch accumulation. A Supervisory message is transmitted every 60 seconds when heating is turned off and every 15 seconds when heating is turned on.

The RS-232 interface is as follows:

Bits per Second (baud rate): 9600

Data bits: 8

Parity: None

Stop bits: 1

Flow control: None

Note: The # sign after a parameter value indicates an invalid value.

Wind data

Example:

0r1,Dn=240D,Dm=249D,Dx=260D,Sn=4.3S,Sm=4.9S,Sx=5.4SMCO

where

0r1 = Wind message

Dn = Wind direction minimum (D = degrees)

Dm = Wind direction average (D = degrees)

Dx = Wind direction maximum (D = degrees)

Sn = Wind speed minimum (S = mph)

Sm = Wind speed average (S = mph)

Sx = Wind speed maximum (S = mph)

MCO = CRC-16 code

PTU Data

Example :

0r2,Ta=73.4F,Ua=26.3P,Pa=29.71IE^x

where

0r2 = Temperature, Pressure and Humidity message

Ta = Air temperature (F = °F)

Ua = Relative humidity (P = % RH)

Pa = Air pressure (I = Inches Hg)

E^x = CRC-16 code

Precipitation Data:

Example:

0r3,Rc=0.010I,Rd=2530s,Ri=0.01I,Hc=0I,Hd=0s,Hi=0INmo

where

0r3 = Precipitation message

Rc = Rain accumulation (I = inches)

Rd = Rain duration (s = seconds)

Ri = Rain intensity (I = inches/h)

Hc = Hail accumulation (M = hits/in²)

Hd = Hail duration (s = seconds)

Hi = Hail intensity (M = hits/ in²h)

Nmo = CRS-16 code

Note: Precipitation data is reset to zero after the record is transmitted.

Supervisory Data:

Example:

0r5,Th=69.0F,Vh=0.0N,Vs=17.0V,Vr=3.483VCa~

where

0r5= Supervisory message

Th = Heating temperature (F = °F)

Vh = Heating voltage (N = heating is off)

Vs = Supply voltage (V = V)

Vr= 3.5 V reference voltage (V = V)

Ca~ = CRS-16 code

Connecting the Orion Sensor to a Computer

Connect the provided RS-232 cable to either serial port on the Interface Module. Connect the other end of the RS-232 cable and DB-9 connector to an available serial port on the computer.

A serial to USB converter may be required if the computer or laptop does not have a serial port installed.

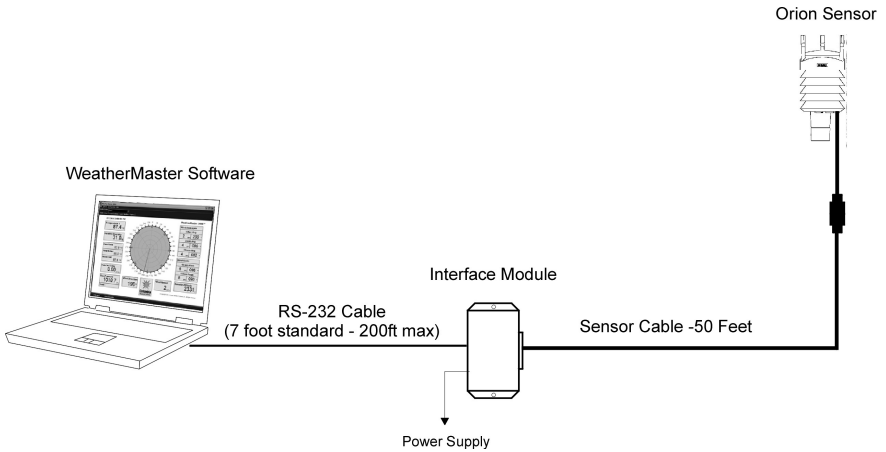

Connecting the Orion Sensor to the Weather MicroServer

Orion Sensor

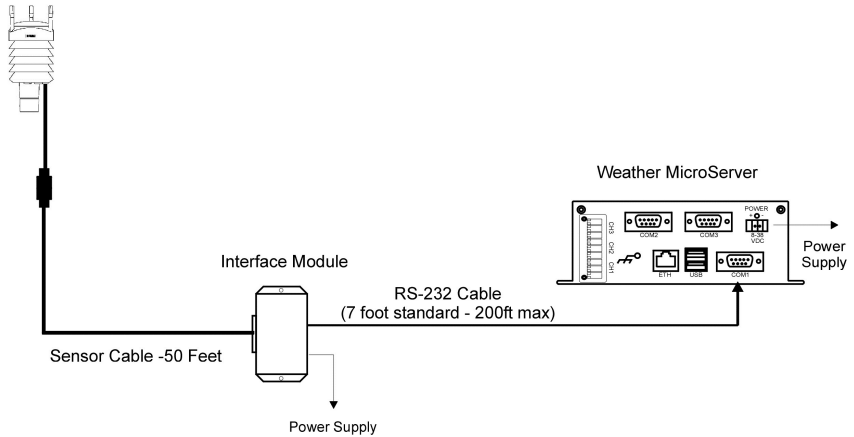

Connect the provided RS-232 cable to either serial port on the Interface Module. Connect the other end of the cable and DB-9 connector to COM 1 on the MicroServer, securing it with the attached screws.

Connecting the Orion Sensor to the Weather Display Console

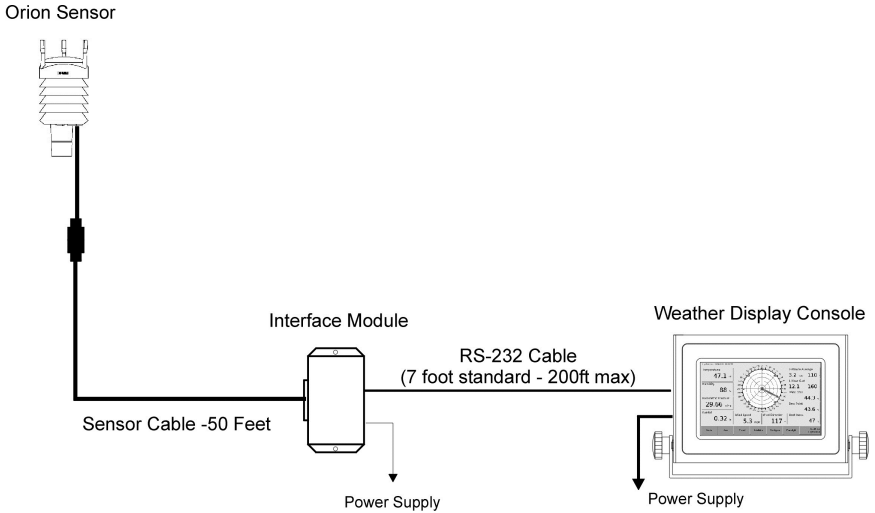

Connect the provided RS-232 cable to either serial port on the Interface Module. Connect the other end of the cable to the serial port (bottom port) on the Weather Display Console.

CRC-16 Computation

The computation of the CRC is performed on the data response before parity is added. All operations are assumed to be on 16 bit unsigned integers. The least significant bit is on the right. Numbers preceded by 0x are in hexadecimal. All shifts shift in a zero. The algorithm is:

Initialize the CRC to zero. For each character beginning with the address, up to but not including the carriage return (<cr>), do as follows:

```
{
    Set the CRC equal to the exclusive OR of the
    character and itself
    for count =1 to 8
    {
        if the least significant bit of the CRC
        is one
        {
            right shift the CRC one bit
            set CRC equal to the exclusive OR
            of 0xA001 and itself
        }
        e
    lse
        {
            right shift the CRC one bit
        }
    }
}
```

Encoding the CRC as ASCII Characters

The 16 bit CRC is encoded to three ASCII characters by using the following algorithm:

1st character = $0x40$ OR (CRC shifted right 12 bits)

2nd character = $0x40$ OR ((CRC shifted right 6 bits) AND $0x3F$)

3rd character = $0x40$ OR (CRC AND $0x3F$)

The three ASCII characters are placed between the data and <cr><lf>. Parity is applied to all three characters, if selected for the character frame.

The CRC computation code is added to the end of the response, if the first letter of the command is sent by using lower case.

SECTION 7: CALIBRATION

Factory Calibration

The wind sensor is checked in a zero wind verifier that meets Vaisala's manufactured specifications. The pressure, temperature and relative humidity module is tested against a Vaisala PTU200 working standard. The measurement of humidity, temperature and pressure are each verified against the PTU200 working standard prior to shipment. The PTU200 pressure measurement is calibrated against a Vaisala PTB220 barometer and is traceable to the National Institute of Standards and Technology (NIST) via Vaisala's Measurement Standards Laboratory (MSL). The PTU200 temperature measurement is calibrated against a Hart 1560 working standard in a liquid bath at Vaisala's MSL and is traceable to NIST. The PTU200 humidity measurement is calibrated against two Vaisala HMP233 working standards which are calibrated against a HYGRO M3 dewpoint meter. The HYGRO M3 dewpoint meter is calibrated in Vaisala's MSL and is traceable to NIST. Vaisala's MSL has been accredited by FINAS according to ISO.IEC 17025.

The Zero wind verifier measures the ultrasonic speed transmitter and received in zero-wind environment. Once this is calibrated, the wind readings will be accurate over the full range of the sensor.

Temperature and Pressure Reading Adjustments

Even though the temperature sensor is calibrated at the factory to $\pm 0.5^{\circ}\text{F}$ and requires no further calibration, and similarly the pressure sensor is calibrated to ± 0.015 inches Hg, the sensors reading can be adjusted using WeatherMaster software or the Weather Display console. Please refer to their user manual for more information.

SECTION 8: MAINTENANCE

This chapter contains instructions for the basic maintenance of the sensor transmitter.

Cleaning

To ensure the accuracy of measurement results, the sensor transmitter should be cleaned when it becomes contaminated. Leaves and other such particles should be removed from the precipitation sensor and the transmitter should be cleaned carefully with a soft, lint-free cloth moistened with mild detergent.

Replacing the PTU Module

Note: Avoid contacting the white filter cap with your hands. Handle the PTU module from the plastic connector base (5).

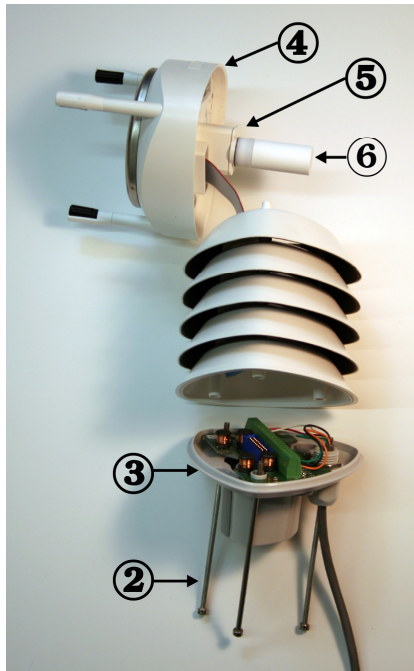

1. Disconnect Orion sensor connector from cable and remove from mounting adapter.
2. Loosen the three screws at the bottom of sensor and slide out completely as shown below.

3. Remove the base section and disconnect the flat ribbon cable.
4. Pull out the top of the sensor.
5. Release the small white flap and remove the PTU module.
6. Connect a new PTU module, replace the top, re-connect the flat ribbon cable, replace the base and tighten the three bottom screws.
7. Re-install on mounting adapter and reconnect cable connector.

Factory Calibration and Repair Service

Send the device to Columbia Weather Systems, Inc. for calibration and adjustment, see USER SUPPORT INFORMATION section for more information.

SECTION 9: TROUBLESHOOTING

This chapter describes common problems, their probable causes and remedies.

Problem	Possible Cause	Action
Loss of communication from Orion sensor module	Blown fuse Poor cable connection Surge protector tripped	Check the Interface Module fuse, replace if needed. Check all cable connections between sensor and optional monitoring device.
Pressure, humidity or temperature measurement failure.	PTU module may not be properly connected. There may be water in the PTU module.	Ensure the proper connection/seating of the PTU module. Remove and dry the module.
Wind measurement failure. Both the speed and direction sensors are not reporting correct data	Blockage (trash, leaves, branches, debris) between the wind transducers. Confirm the wind transducers are not damaged.	Remove the blockage.

Loss of communication with Orion sensor module:

- Check the Interface Module. If the Green Power LED and Red Power LED are out, it is possible that the fuse has blown. Disconnect power and remove the four screws on the front panel of the Interface Module to check the fuse.
- Check all weatherproof cable connectors between the Orion sensor and any optional monitoring device; e.g., MicroServer, Display Console. Look for broken or damaged pins. Also inspect the cable connectors for water intrusion.
- If a surge protector was purchased and installed, an electrical event may have tripped the protector. Test for loss of communication by bypassing the surge protector and establish a direct cable connection. Determine if communication has been reestablished. To purchase a replacement surge protector please call 1-503-629-0887 and reference Part No. 8355.

Wind measurement failure:

- If both the wind speed and direction sensors are not reporting correct data check to see if a blockage (trash, leaves, branches, debris) exists between the wind transducers. If this is the case remove the blockage and verify that wind reports have continued. Also confirm that the wind transducers are not damaged. If they are damaged please follow the “Return for Repair Procedure” in Section 10.

Pressure, humidity and temperature measurement failure:

- The PTU module may not be properly connected. Ensure the proper connection of the PTU module by following the “Replacing PTU module” procedure in Section 8. There may be water in the PTU module. Remove and dry the module before reconnecting the sensor.

SECTION 10: USER SUPPORT INFORMATION

This section consists of the following items:

1. **One-Year Limited Warranty:** Please read this document carefully.
2. **Return for Repair Procedure:** This procedure is for your convenience in the event you must return your Orion for repair or replacement. Follow the packing instructions carefully to protect your instrument in transit.

Limited Warranty

Columbia Weather Systems, Inc. (CWS), warrants the Orion Weather Station to be free from defects in materials and/or workmanship when operated in accordance with the manufacturer's operating instructions, for one (1) years from date of purchase, subject to the provisions contained herein. CWS warranty shall extend to the original purchaser only and shall be limited to factory repair or replacement of defective parts.

EXCLUSIONS

Certain parts are not manufactured by CWS (i.e., certain purchased options, etc.) and are therefore not covered by this warranty. These parts may be covered by warranties issued by their respective manufacturers and although CWS will not warrant these parts, CWS will act as agent for the administration of any such independent warranties during the term of this warranty. This warranty does not cover normal maintenance, damage resulting from improper use or repair, or abuse by the operator. Damage caused by lightning or other electrical discharge is specifically excluded. This warranty extends only to repair or replacement, and shall in no event extend to consequential damages. In the event of operator repair or replacement, this warranty shall cover neither the advisability of the repair undertaken, nor the sufficiency of the repair itself.

THIS DOCUMENT REFLECTS THE ENTIRE AND EXCLUSIVE UNDERSTANDING OF THE PARTIES, AND EXCEPT AS OTHERWISE PROVIDED HEREIN, ALL OTHER WARRANTIES, EXPRESS OR IMPLIED, PARTICULARLY THE WARRANTIES OF MERCHANT

ABILITY AND/OR FITNESS FOR A PARTICULAR PURPOSE ARE EXCLUDED.

This warranty gives you specific legal rights, and you may also have other rights which vary from state to state.

Return for Repair Procedure

1. In the event of defects or damage to your unit, first call the Service Department Monday through Friday, 8:30 am to 4:00 pm PST, (503) 629-0887 to determine the advisability of factory repair. The Service Department will issue an RMA number (Return Merchandise Authorization) to help us identify the package when received. Please write that number on the outside of the box.
2. In the event factory service is required, return your Orion Weather Station as follows:
 - A. Packing
 - ◆ Wrap the Sensor Transmitter in a plastic bag first.
 - ◆ Pack in original shipping carton or a sturdy oversized carton.
 - ◆ Use plenty of packing material.
 - B. Include:
 - ◆ A brief description of the problem with all known symptoms.
 - ◆ Your telephone number.
 - ◆ Your return street shipping address (UPS will not deliver to a P.O. box).
 - ◆ Write the RMA number on the outside of the box.
 - C. Shipping
 - ◆ Send freight prepaid (UPS recommended).
 - ◆ Insurance is recommended. (The factory can provide the current replacement value of the item being shipped for insurance purposes.)

D. Send to:

Columbia Weather Systems, Inc.
5285 NE Elam Young Parkway, Suite C100
Hillsboro, Oregon 97124

E. C.O.D. shipments will not be accepted.

3. If your unit is under warranty, after repair or replacement has been completed, it will be returned by a carrier and method chosen by Columbia Weather, Inc. to any destination within the continental U.S.A. If you desire some other specific form of conveyance or if you are located beyond these borders, then you must bear the additional cost of return shipment.
4. If your unit is not under warranty, we will call you with an estimate of the charges. If approved, your repaired unit will be returned after all charges, including parts, labor and return shipping and handling, have been paid. If not approved, your unit will be returned as is via UPS COD for the amount of the UPS COD freight charges.

Reference

Glossary

Aspirating Radiation Shield

A device used to shield a sensor such as a temperature probe from direct and indirect radiation and rain while providing access for ventilation.

Barometric Pressure

The pressure exerted by the atmosphere as a consequence of gravitational attraction exerted upon the “column” of air lying directly above the point in question.

Celsius Temperature Scale

A temperature scale with the ice point at 0 degrees and the boiling point of water at 100 degrees.

Dew Point

The temperature to which a given parcel of air must be cooled at constant pressure and constant water-vapor content in order for saturation to occur. When this temperature is below 0°C, it is sometimes called the frost point.

Density Altitude

Density altitude is a meteorological variable that is important to pilots, especially during the summer. The density altitude is the altitude in a standard atmosphere where the density is the same as the given atmospheric density. During a hot muggy summer day, a pilot begins take off from an airport with an elevation of 2500 feet. Because of the warm temperature and the moisture in the air, the airplane has to work as if it was taking off at an airport at an elevation of 6000 feet resulting in the plane needing more power and a longer roll down the runway to take off.

Fahrenheit Temperature Scale

A temperature scale with the ice point at 32 degrees and the boiling point of water at 212 degrees.

Global Radiation

The total of direct solar radiation and diffused sky radiation received by a unit horizontal surface. Global radiation is measured by a pyranometer.

Heat Index

The heat index or apparent temperature is a measure of discomfort due to the combination of heat and high humidity. It was developed in 1979 and is based on studies of evaporative skin cooling for combinations of temperature and humidity.

Pyranometer

It measures the combined intensity of incoming direct solar radiation and diffused sky radiation. The pyranometer consists of a radiation-sensing element, which is mounted so that it views the entire sky.

Relative Humidity

Popularly called humidity. The ratio of the actual vapor pressure of the air to the saturation vapor pressure.

Sea Level Pressure

The atmospheric pressure at mean sea level, either directly measured or, most commonly, empirically determined from the observed station pressure.

In regions where the earth's surface pressure is above sea level, it is standard observational practice to reduce the observed surface pressure to the value that would exist at a point at sea level directly below.

Solar Radiation

The total electromagnetic radiation emitted by the sun. 99% of the sun's energy output falls within the wavelength interval from 0.15 microns to 4.0 microns, with peak intensity near 0.47 microns. About one-half of the total energy in the solar beam is contained within the visible spectrum from 0.4 to 0.7 microns, and most of the other half lies near infrared, a small additional portion lying in the ultraviolet.

Wind Chill

That part of the total cooling of a body caused by air motion.

Unit Conversion

Speed

Kilometers per hour = 1.610 x miles per hour

Knots = 0.869 x miles per hour

Meters per second = 0.448 x miles per hour

Feet per second = 1.467 x miles per hour

Temperature

Temperature in °C = 5/9 (temperature in °F - 32)

Temperature in °F = (1.8 x temperature in °C) + 32

Distance

Millimeters = 25.4 x inches

Pressure

Millibars = 33.86 x inches of mercury

Kilopascals = 3.386 x inches of mercury

Pounds per square inch = 0.49 x inches of mercury

Standard atmospheres = 0.0334 x inches of mercury

Tables and Formulas

Wind Chill Chart

In 2001, NWS implemented an updated Wind chill Temperature (WCT) index. The change improves upon the former WCT Index used by the NWS and the Meteorological Services of Canada, which was based on the 1945 Siple and Passel Index.

In the fall of 2000, the Office of the Federal Coordinator for Meteorological Services and Supporting Research (OFCM) formed a group consisting of several Federal agencies, MSC, the academic community (Indiana University-Purdue University in Indianapolis (IUPUI), University of Delaware and University of Missouri), and the International Society of Biometeorology to evaluate and improve the windchill formula. The group, chaired by the NWS, is called the Joint Action Group for temperature Indices (JAG/TI). JAG/TI's goal is to upgrade and standardize the index for temperature extremes internationally (e.g. Wind chill Index).

The current formula uses advances in science, technology, and computer modeling to provide a more accurate, understandable, and useful formula for calculating the dangers from winter winds and freezing temperatures.

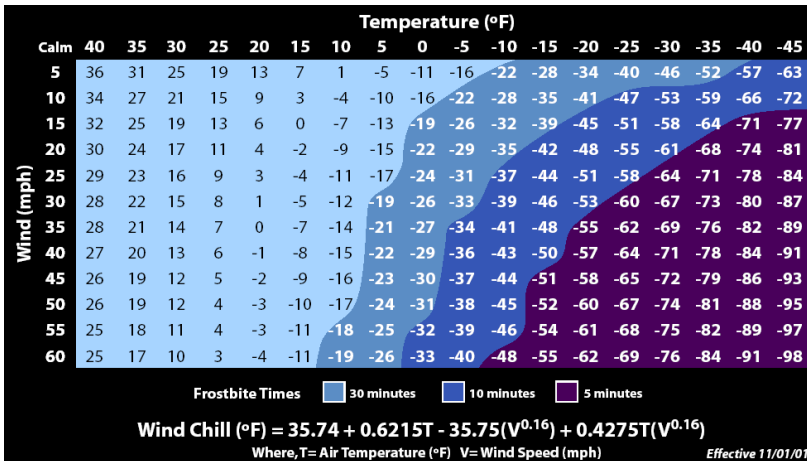

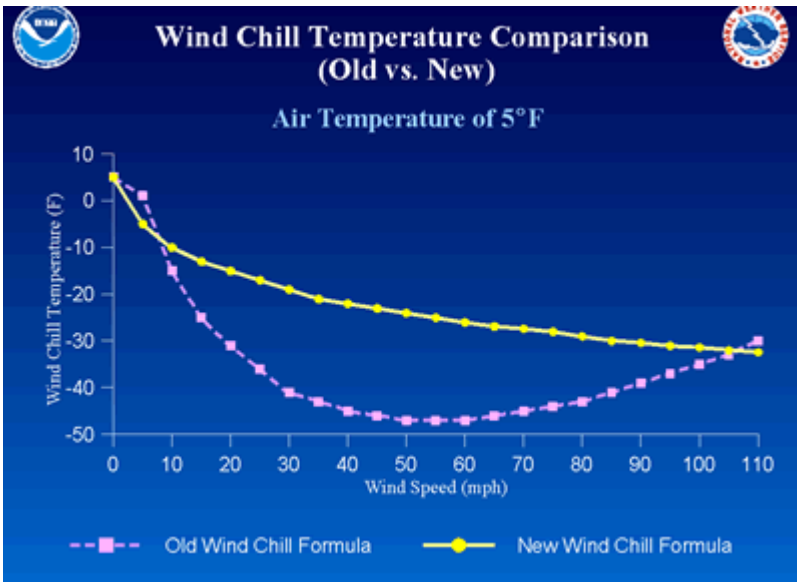

Wind Chill Equation

$$WC = 35.74 + 0.6215 T - 35.75(V^{0.16}) + 0.4275 T(V^{0.16})$$

Where:

WC = wind chill temperature in °F

V = wind velocity in mph

T = air temperature in °F

Note: Wind chill Temperature is only defined for temperatures at or below 50 degrees F and wind speeds above 3 mph.

Heat Index

RH	Temperature in °F													
	70	75	80	85	90	95	100	105	110	115	120	125	130	135
0	64	66	73	78	83	87	91	95	99	103	107	111	117	120
5	64	69	74	79	84	88	93	97	102	107	111	116	122	126
10	65	70	75	80	85	90	95	100	105	111	116	123	131	
15	65	71	76	81	86	91	97	102	108	115	123	131		
20	66	72	77	82	87	93	99	105	112	120	130	141		
25	66	72	77	83	88	94	101	109	117	127	139			
30	67	73	78	84	90	96	104	113	123	135	148			
35	67	73	79	85	91	98	107	118	130	143				
40	68	74	79	86	93	101	110	123	137	151				
45	68	74	80	87	95	104	115	129	143					
50	69	75	81	88	96	107	120	135	150					
55	69	75	81	89	98	110	126	142						
60	70	76	82	90	100	114	132	149						
65	70	76	83	91	102	119	138							
70	70	77	84	93	106	124	144							
75	70	77	85	95	109	130	150							
80	71	78	86	97	113	136								
85	71	78	87	99	117	140								
90	71	79	88	102	122	150								
95	71	79	89	105	126									
100	72	80	90	108	131									

Dew Point

$$B = (\ln (RH/100) + ((17.2694 * T) / (238.3 + T))) / 17.2694$$

$$\text{Dew Point in } ^\circ\text{C} = (238.3 * B) / (1 - B)$$

Where:

RH = Relative Humidity

T = Temperature in $^\circ\text{C}$

Ln = Natural logarithm



Columbia Weather Systems, Inc.
5285 NE Elam Young Parkway, Suite C100
Hillsboro, OR 97124

Telephone

(503) 629-0887

Fax

(503) 629-0898

Web Site

<http://www.columbiaweather.com>

Email

info@columbiaweather.com

Part Number: 81650

Version 2.07

Printed in U.S.A.