Thermo[®]-Expansion Valves

Expansion Valves

Basic Terms and Technical Information

Operating principles

ALCO Thermo®-Expansion valves control the superheat of refrigerant vapour at the outlet of the evaporator. They act as a throttle device between the high pressure and the low pressure sides of refrigeration systems and ensure that the rate of refrigerant flow into the evaporator exactly matches the rate of evaporation of liquid refrigerant in the evaporator. Thus the evaporator is fully utilized and no liquid refrigerant may reach the compressor.

Description of bulb charges

The application ranges of Thermo®-Expansion valves are heavily influenced by the charge selected.

Liquid charges

The behaviour of Thermo®-Expansion valves with liquid charges is exclusively determined by temperature changes at the bulb and not subject to any cross-ambient interference. They feature a fast response time and thus react quickly in the control circuit. Liquid charges cannot incorporate MOP functions. Maximum bulb temperatures shall not exceed 75° C.

Gas charges

The behaviour of Thermo®-Expansion valves with gas charges will be determined by the lowest temperature at any part of the expansion valve (power assembly, capillary tube or bulb). If any parts other than the bulb are subject to the lowest temperature, malfunction of the expansion valve may occur (i.e. erratic low pressure or excessive superheat). ALCO thermo expansion valves with gas charges always feature MOP functions and include ballasted bulbs. Ballast in the bulb leads to slow opening and fast closure of the valve. Maximum bulb temperature is 120° C.

Adsorption charges

These charges feature control characteristics much like MOP charges but avoid the difficulties of cross-ambient interference. Response time is slow but perfectly suitable for common refrigeration systems. Maximum bulb temperature is 130° C.

MOP (Maximum Operating Pressure)

MOP functionality is somewhat similar to the application of a crankcase pressure regulator. Evaporator pressures are limited to a maximum value to protect compressor from overload conditions.

MOP selection should be within maximum allowed low pressure rating of the compressor and should be at approximately 3K above evaporating temperatures.

Practical hint: Superheat adjustments influence the MOP:

Increase of superheat: Decrease of MOP
Decrease of superheat: Increase of MOP

Static superheat

ALCO Thermo®-Expansion valves are factory preset for optimum superheat settings. This setting should be modified only if absolutely necessary.

The readjustment should be at the lowest expected evaporating temperature.

Subcooling

Subcooling generally increases the capacity of refrigeration system and may be accounted for when dimensioning an expansion valve by applying the correction factor K_t . The capacity corrections for evaporating temperature, condensing temperature and subcooling are all incorporated in K_t . These are in particular the liquid density upstream from the expansion valve, the different enthalpies of liquid and vapour phase refrigerants as well as certain part of flash gas after expansion. The percentage of flash gas differs with various refrigerants and depends on system conditions.

Heavy subcooling results in very small flash gas amounts and therefore increases expansion valve capacities. These conditions are not covered by K_t . Likewise, small flash gas amounts lead to reduced evaporator capacities and may result in substantial discrepancies between the capacities of the Thermo®-expansion valve and the evaporator. These effects must be considered during component selection when designing refrigeration circuits. In cases when subcooling exceeds 15 K, sizing of components (K_t , $K_{\Delta p}$) should be modified accordingly. The field practice indicates the following correction factors can be used to compensate the effect of the subcooling (liquid hammering) in addition to the use of correction factors K_t , and $K_{\Delta p}$.

Subcooling	20K	30K	40K	50K	60K
Correction factor	0,8	0,7	0,6	0,5	0,4

ALCO CONTROLS will be happy to assist you. Please contact application engineering department.

Dimensioning

To correctly select a Thermo®-Expansion valve on a system, the following design conditions must be available:

- Cooling capacity Q_o
- Effective pressure differential across Thermo®-Expansion valve Δp
- Evaporating temperature/pressure
- Lowest possible condensing temperature/pressure
- Liquid temperature
- Type of refrigerant

As opposed to single substances (e.g. R22, R134a etc.) where the phase change takes place at a constant temperature/pressure, the evaporation and condensation of **zeotropic blend R407C** is in a gliding form (e.g. at a constant pressure the temperature varies within a certain range) through evaporators and condensers.

The evaporating/condensing pressure must be determined at saturated temperatures (bubble/dew points) for dimensioning of Thermo®-Expansion valves.

To facilitate **valve dimensioning** for other than the standard conditions ALCO offers an Excel based **Selection Tool**. This can be ordered from all Emerson sales offices. See www.emersonclimate.eu for contact addresses, email or phone numbers.

Example

Cooling capacity of a system: 18 kW
 Refrigerant: R 407C
 Condensing temperature (saturated liquid): +35°C
 (Condensing pressure will be 15.5 bar)
 See appendix page 153 for
 Evaporating temperature (saturated vapour): 0°C
 (Evaporating pressure will be 4.61 bar)
 Subcooling: 1 K
 Pressure drops through liquid line: 2.2 bar
 Pressure drops through evaporator: 0.3 bar
 Required type of Thermo®-Expansion valve:T-series

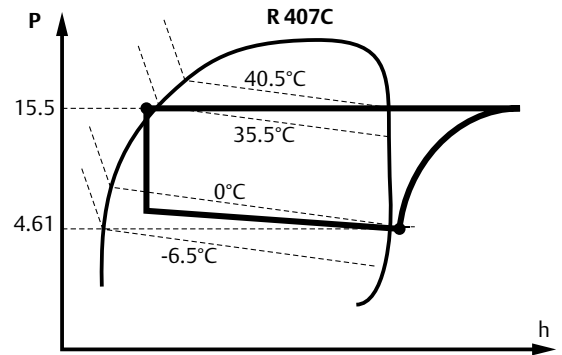

To calculate the nominal capacity the following formula has to be used:

Cooling capacity x Kt x K_{Δp} = Nominal capacity

1. Selected **Kt-factor** according to refrigerant, liquid and evaporating temperature from table on page 76.

$K_t = 0.98$ (for this example)

2. Determine pressure differential across the Thermo®-Expansion valve using condensing pressure, subtract evaporating pressure and all other possible pressure losses (pressure drops in evaporator, drier, solenoid valve, liquid distribution...).

For this example:

$\Delta p = 15.5 - (4.61 + 2.2 + 0.3) = 8.39 \text{ bar}$

Select **K_{Δp}** factor from table on page 76:

$K_{\Delta p} = 1,15$ (for this example)

3. Multiply cooling capacity with **Kt** and **K_{Δp}**, to find nominal capacity for Thermo®-Expansion valve.

$Q_n = 18 \times 0.98 \times 1.15 = 20.29 \text{ kW}$

Select Thermo®-Expansion Valve from table on page 72: TCLE 550 NW (for this example).

Please note that all evaporating/condensing temperatures in this catalogue are based on saturated vapour/liquid temperatures.

Selection Guide for Expansion Valves

Series	Selection Criteria				Catalogue Page
	Capacity Range kW (R 404A)	Evaporating Temperature Range °C	Main Application	Features	
TI	0,5 to 14,2	+20 to -45	Refrig./Air-Cond. Heat Pumps	Interchangeable Orifices	66
TX3	0,8 to 15,0	+20 to -45	Refrig./Air-Cond. Heat Pumps	Hermetic, Superheat adjustable, optional with check valve	72
TX6	13.3 to 57.0	+20 to -45	Air-Cond. Heat Pumps	Hermetic Superheat adjustable	74
T	2 to 209	+30 to -45	Refrig./Air-Cond. Heat Pumps	Interchangeable Orifices, Power-Assembly and Flange	76
ZZ	1,9 to 81,2	-45 to -120	Low Temperature Application	Interchangeable Orifices, Power-Assembly and Flange	81
L	2 to 154	+30 to -50	Liquid Injection Superheat Control	Interchangeable Orifices, Power-Assembly and Flange	84
935	5,2 to 43,5	+30 to -45	Liquid Injection Temperature Control	Interchangeable Orifices, Power-Assembly and Flange	86

* Please ask your local Emerson sales office for datasheets or download from www.emersonclimate.eu

Thermo®-Expansion Valve Series T

Exchangeable Power Assemblies and Orifices

Features

- Modular design for economical logistics and easy assembly and servicing
- Very good stability is attained because of the large forces generated by the large diaphragm diameter
- High quality materials and processes for high reliability and long lifetime
- Superior partial load performance due to double seat orifice design (TJRE, TERE, TIRE & THRE)
- Biflow capability for applications in heat pumps
- Capillary tube length 1.5 m (TCLE, TJRE) and 3m (TERE, TIRE & THRE)
- PS: 31 bar, TS: -45 ... +65°C
- No CE marking according art. 3.3 PED 97/23 EC



Type Code

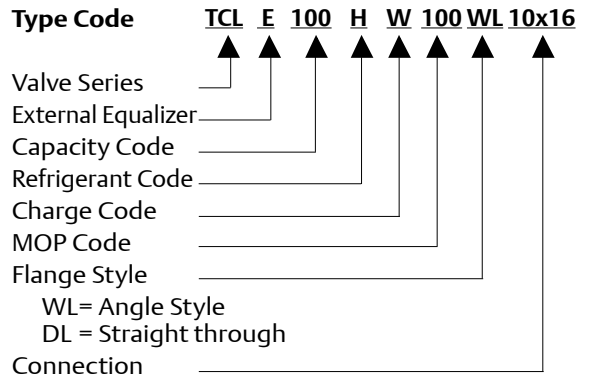

Selection Chart for Orifices

Series	R 134a		R 22		R 404A/R 507		R 407C		Orifice
	Type	Nominal Capacity kW	Type	Nominal Capacity kW	Type	Nominal Capacity kW	Type	Nominal Capacity kW	
TCLE	25 MW	1,5	50 HW	1,9	25 SW	1,3	50 NW	2,1	X 22440-B1B
	75 MW	2,9	100 HW	3,7	75 SW	2,6	100 NW	4,0	X 22440-B2B
	150 MW	6,1	200 HW	7,9	150 SW	5,6	200 NW	8,5	X 22440-B3B
	200 MW	9,3	250 HW	11,9	200 SW	8,4	300 NW	12,9	X 22440-B3,5B
	250 MW	13,5	300 HW	17,3	250 SW	12,2	400 NW	18,7	X 22440-B4B
	350 MW	17,3	500 HW	22,2	400 SW	15,7	550 NW	24,0	X 22440-B5B
	550 MW	23,6	750 HW	30,4	600 SW	21,5	750 NW	32,9	X 22440-B6B
	750 MW	32,0	1000 HW	41,1	850 SW	29,0	1000 NW	44,4	X 22440-B7B
TJRE	11 MW	45	14 HW	58	12 SW	40	14 NW	62	X 11873-B4B
	13 MW	57	18 HW	74	14 SW	51	17 NW	80	X 11873-B5B
TERE	16 MW	71	22 HW	91	18 SW	63	21 NW	99	X 9117-B6B
	19 MW	81	26 HW	104	20 SW	72	25 NW	112	X 9117-B7B
	25 MW	112	35 HW	143	27 SW	99	33 NW	155	X 9117-B8B
	31 MW	135	45 HW	174	34 SW	120	42 NW	188	X 9117-B9B
TIRE	45 MW	174	55 HW	223	47 SW	154	52 NW	241	X 9166-B10B
THRE	55 MW	197	75 HW	253	61 SW	174	71 NW	273	X 9144-B11B
	68 MW	236	100 HW	302	77 SW	209	94 NW	327	X 9144-B13B

Nominal capacity (Qn) is based on the following conditions:

MOP Code	MOP bar	Evaporating Temperature Range °C				
		R 134a MW	R 22 HW	R 404A SW	R 407C NW	R 507 SW
35	2,4	-45 .. 0	-45 .. -15			
40	2,8			-45 .. -18		-45 .. -18
55	3,8	-45 .. 11		-45 .. -10		-45 .. -10
65	4,5		-45 .. 0			
75	5,2			-45 .. -2		-45 .. -2
80	5,5			-45 .. 0		-45 .. 0
100	6,9		-45 .. 13		-45 .. 14	

Refrigerant	Evaporating temperature	Condensing temperature	Sub-cooling
R 407C	+4°C dew point	+38°C bubble p. +43°C dew point	1K
R 22, R 134a, R 404A/R 507	+4°C	+38°C	1K

Valve selection for other operating conditions see page 74 or use the Excel based ALCO Selection Tool (download from www.emersonclimate.eu).

Available upon special request:

- Power assembly with solder connection for external pressure equalization
- Non-standard MOPs
- Non-standard charges
- Non-standard connection sizes, see page 86

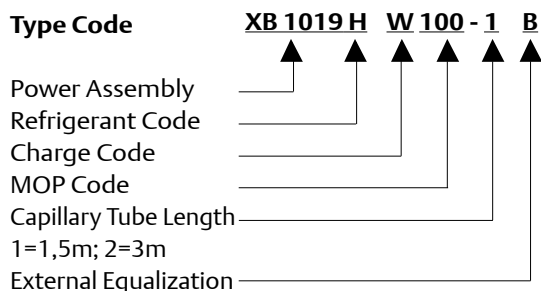

Selection Chart for Power Assemblies and Recommended Flanges

	Orifice	Connection		Power Assembly
		Standard-Flange, Angle (see page 86)		
		mm	inch	
	X 22440-B1B	C 501 - 5 mm 10 x 16	C 501 - 5 3/8 x 5/8	XB1019...1B
	X 22440-B2B			
	X 22440-B3B			
	X 22440-B3,5B			
	X 22440-B4B			
	X 22440-B5B	C 501 - 7 mm 12 x 16	C 501 - 7 1/2 x 5/8	
	X 22440-B6B			
	X 22440-B7B	A 576 mm 16 x 22 (22 x 28 ODM)	A 576 5/8 x 7/8 (7/8 x 1 1/8 ODM)	
	X 22440-B8B			
	X 11873-B4B			10331 22 x 22
	X 11873-B5B			
	X 9117-B6B	9153 mm 22 x 22	9153 7/8 x 7/8 (1 1/8 x 1 1/8 ODM)	XC726...2B
	X 9117-B7B			
	X 9117-B8B			
	X 9117-B9B			
	X 9166-B10B			
	X 9144-B11B	9149 22 x 22	9149 7/8 x 7/8 (1 1/8 x 1 1/8 ODM)	
	X 9144-B13B			

Spare Parts

	Type	Part No.
Gasket Set for T Series Valves	X 13455 -1	027 579
Service Tool for T Series	X 99999	800 005
Steel screws for following flange types:		
C501 , 9761 , 6346 , A576	Screw ST 32	803 573
9148 , 9149, 9152, 9153, 10331 , 10332	Screw ST 48	803 574

Correction Tables for Thermo®-Expansion Valves Series TI, TX3, TX6, T and L

Valve selection for operating conditions other than nominal conditions:

Alternatively download the Excel based ALCO Selection Tool from www.emersonclimate.eu.

$$Q_n = Q_o \times K_t \times K_{\Delta p}$$

Q_n : Nominal valve capacity

K_t : Correction factor for evaporating and liquid temperature

Q_o : Required cooling capacity

$K_{\Delta p}$: Correction factor for pressure drop at valve

Liquid Temperature entering Valve °C	Correction Factor K_t															
	R 410A (TX3/6 only) Evaporating Temperature °C															
	+20	+15	+10	+5	0	-5	-10	-15	-20	-25	-30	-35	-40	-45		
+65	1,75	1,76	1,78	1,80	1,83	1,86	1,89	2,18	2,55	3,05	3,69	4,49	5,46	6,62		
+60	1,49	1,50	1,51	1,53	1,54	1,57	1,59	1,83	2,14	2,55	3,08	3,73	4,52	5,45		
+55	1,31	1,32	1,33	1,35	1,36	1,38	1,40	1,61	1,87	2,23	2,68	3,25	3,92	4,72		
+50	1,19	1,20	1,20	1,21	1,23	1,24	1,26	1,44	1,68	2,00	2,40	2,90	3,49	4,20		
+45	1,09	1,09	1,10	1,11	1,12	1,13	1,15	1,32	1,53	1,82	2,18	2,63	3,17	3,80		
+40	1,01	1,01	1,02	1,03	1,04	1,05	1,06	1,21	1,41	1,67	2,01	2,41	2,90	3,48		
+35	0,94	0,94	0,95	0,96	0,97	0,98	0,99	1,13	1,31	1,55	1,86	2,24	2,69	3,21		
+30	0,88	0,89	0,89	0,90	0,91	0,91	0,92	1,06	1,22	1,45	1,74	2,09	2,50	2,99		
+25	0,83	0,84	0,84	0,85	0,85	0,86	0,87	0,99	1,15	1,36	1,63	1,96	2,35	2,80		
+20		0,79	0,80	0,80	0,81	0,81	0,82	0,94	1,09	1,29	1,54	1,84	2,21	2,64		
Correction Factor $K_{\Delta p}$																
Δp (bar)	1	2	3	4	5	6	7	8	9	10	11	12	13	14	15	16
$K_{\Delta p}$	3,74	2,65	2,16	1,87	1,67	1,53	1,41	1,32	1,25	1,18	1,13	1,08	1,04	1	0,97	0,94
Δp (bar)	17	18	19	20	21	22	23	24	25	26	27	28	29	30	31	32
$K_{\Delta p}$	0,91	0,88	0,86	0,84	0,82	0,8	0,78	0,76	0,75	0,73	0,72	0,71	0,69	0,68	0,67	0,66

Liquid Temperature entering Valve °C	Correction Factor K_t															
	R 134a Evaporating Temperature °C															
	+30	+25	+20	+15	+10	+5	0	-5	-10	-15	-20	-25	-30			
+60	1,22	1,25	1,27	1,30	1,33	1,36	1,40	1,44	1,48	1,75	2,08	2,46	2,94			
+55	1,14	1,16	1,18	1,21	1,23	1,26	1,29	1,33	1,36	1,60	1,90	2,25	2,68			
+50	1,07	1,08	1,10	1,13	1,15	1,17	1,20	1,23	1,26	1,48	1,76	2,07	2,46			
+45	1,00	1,02	1,04	1,06	1,08	1,10	1,12	1,15	1,17	1,38	1,63	1,92	2,28			
+40	0,93	0,96	0,98	0,99	1,01	1,03	1,05	1,08	1,10	1,29	1,52	1,79	2,12			
+35	0,90	0,91	0,92	0,94	0,96	0,97	0,99	1,01	1,03	1,21	1,43	1,68	1,99			
+30	0,85	0,86	0,88	0,89	0,91	0,92	0,94	0,96	0,98	1,14	1,35	1,58	1,87			
+25		0,82	0,83	0,85	0,86	0,87	0,89	0,91	0,92	1,08	1,27	1,49	1,76			
+20			0,80	0,81	0,82	0,83	0,85	0,89	0,88	1,02	1,21	1,41	1,67			
+15				0,77	0,78	0,79	0,81	0,82	0,84	0,97	1,15	1,34	1,58			
+10					0,75	0,76	0,77	0,78	0,80	0,93	1,09	1,28	1,51			
+5						0,73	0,74	0,75	0,76	0,89	1,04	1,22	1,44			
0							0,71	0,72	0,73	0,85	1,00	1,17	1,37			
-5								0,69	0,70	0,82	0,96	1,12	1,31			
-10									0,68	0,79	0,92	1,07	1,26			
Correction Factor $K_{\Delta p}$																
Δp (bar)	0,5	1,0	1,5	2,0	2,5	3,0	3,5	4,0	4,5	5,0	5,5	6,0	6,5	7,0	7,5	8,0
$K_{\Delta p}$	3,50	2,48	2,02	1,75	1,57	1,43	1,32	1,24	1,17	1,11	1,06	1,01	0,97	0,94	0,90	0,88
Δp (bar)	8,5	9,0	9,5	10,0	10,5	11,0	11,5	12,0	13,0	14,0	15,0	16,0	17,0	18,0	19,0	20,0
$K_{\Delta p}$	0,85	0,83	0,80	0,78	0,76	0,75	0,73	0,72	0,69	0,66	0,64	0,62	0,60	0,58	0,57	0,55

In cases of subcooling of more than 15K please use additionally the correction factors on page 60 of this brochure.

Liquid Temperature entering Valve °C	R 22															
	Correction Factor K_t															
	Evaporating Temperature °C															
	+30	+25	+20	+15	+10	+5	0	-5	-10	-15	-20	-25	-30	-35	-40	-45
+60	1,22	1,23	1,24	1,25	1,26	1,28	1,30	1,31	1,38	1,58	1,84	2,16	2,56	3,04	3,55	4,23
+55	1,14	1,15	1,16	1,17	1,19	1,20	1,22	1,23	1,29	1,42	1,72	2,02	2,39	2,83	3,30	3,94
+50	1,08	1,09	1,10	1,11	1,12	1,13	1,15	1,16	1,21	1,39	1,62	1,89	2,24	2,66	3,10	3,68
+45	1,02	1,03	1,04	1,05	1,06	1,07	1,08	1,10	1,15	1,31	1,52	1,79	2,11	2,50	2,91	3,46
+40	0,97	0,98	0,99	1,00	1,01	1,02	1,03	1,04	1,09	1,24	1,45	1,69	2,00	2,37	2,75	3,27
+35	0,92	0,93	0,94	0,95	0,96	0,97	0,98	0,99	1,03	1,18	1,37	1,61	1,89	2,24	2,60	3,09
+30	0,88	0,89	0,90	0,91	0,92	0,93	0,94	0,95	0,99	1,13	1,31	1,55	1,83	2,13	2,47	2,93
+25		0,85	0,86	0,87	0,88	0,89	0,89	0,90	0,94	1,08	1,25	1,46	1,72	2,03	2,36	2,80
+20			0,83	0,83	0,84	0,85	0,86	0,87	0,90	1,03	1,19	1,40	1,64	1,94	2,25	2,66
+15				0,80	0,81	0,81	0,82	0,83	0,87	0,99	1,14	1,34	1,57	1,86	2,15	2,55
+10					0,78	0,78	0,79	0,80	0,83	0,95	1,10	1,28	1,51	1,78	2,06	2,44
+5						0,75	0,76	0,77	0,80	0,91	1,06	1,23	1,45	1,71	1,98	2,34
0							0,73	0,74	0,77	0,88	1,02	1,19	1,39	1,65	1,90	2,25
-5								0,71	0,74	0,85	0,98	1,14	1,34	1,58	1,83	2,17
-10									0,72	0,82	0,95	1,10	1,30	1,53	1,77	2,09
Correction Factor $K_{\Delta p}$																
Δp (bar)	0,5	1,0	1,5	2,0	2,5	3,0	3,5	4,0	4,5	5,0	5,5	6,0	6,5	7,0	8,0	9,0
$K_{\Delta p}$	4,25	3,00	2,46	2,13	1,90	1,74	1,61	1,50	1,42	1,35	1,28	1,23	1,18	1,14	1,06	1,00
Δp (bar)	10,0	11,0	12,0	13,0	14,0	15,0	16,0	17,0	18,0	19,0	20,0	21,0	22,0	23,0	24,0	25,0
$K_{\Delta p}$	0,95	0,91	0,87	0,83	0,80	0,78	0,75	0,73	0,71	0,69	0,67	0,66	0,64	0,63	0,61	0,60

Liquid Temperature entering Valve °C	R 404A															
	Correction Factor K_t															
	Evaporating Temperature °C															
	+30	+25	+20	+15	+10	+5	0	-5	-10	-15	-20	-25	-30	-35	-40	-45
+60	1,56	1,59	1,64	1,69	1,74	1,81	1,88	1,96	2,06	2,43	2,95	3,56	4,37	5,38	6,71	8,47
+55	1,32	1,35	1,38	1,42	1,46	1,50	1,55	1,61	1,68	1,96	2,36	2,83	3,43	4,16	5,12	6,34
+50	1,16	1,18	1,20	1,23	1,26	1,30	1,34	1,38	1,43	1,67	1,99	2,37	2,85	3,43	4,18	5,14
+45	1,04	1,05	1,07	1,10	1,12	1,15	1,18	1,22	1,26	1,46	1,74	2,05	2,46	2,95	3,57	4,35
+40	0,94	0,96	0,97	0,99	1,02	1,04	1,07	1,09	1,13	1,30	1,55	1,82	2,17	2,59	3,13	3,80
+35	0,87	0,88	0,90	0,91	0,93	0,95	0,97	1,00	1,02	1,18	1,40	1,64	1,96	2,33	2,80	3,38
+30	0,81	0,82	0,83	0,84	0,86	0,88	0,90	0,92	0,94	1,08	1,28	1,50	1,78	2,11	2,53	3,05
+25		0,76	0,77	0,79	0,80	0,82	0,83	0,85	0,87	1,00	1,18	1,39	1,64	1,94	2,32	2,79
+20			0,73	0,74	0,75	0,77	0,78	0,80	0,81	0,94	1,10	1,29	1,52	1,80	2,15	2,58
+15				0,70	0,71	0,72	0,73	0,75	0,76	0,88	1,03	1,21	1,42	1,68	2,00	2,40
+10					0,67	0,68	0,69	0,71	0,72	0,83	0,97	1,13	1,34	1,58	1,88	2,25
+5						0,65	0,66	0,67	0,68	0,78	0,92	1,07	1,26	1,49	1,77	2,11
0							0,63	0,64	0,65	0,75	0,88	1,02	1,20	1,41	1,67	2,00
-5								0,61	0,62	0,71	0,83	0,97	1,14	1,34	1,59	1,90
-10									0,60	0,68	0,80	0,93	1,09	1,28	1,52	1,81
Correction Factor $K_{\Delta p}$																
Δp (bar)	0,5	1,0	1,5	2,0	2,5	3,0	3,5	4,0	4,5	5,0	5,5	6,0	6,5	7,0	8,0	9,0
$K_{\Delta p}$	4,55	3,21	2,62	2,27	2,03	1,86	1,72	1,61	1,52	1,44	1,37	1,31	1,26	1,21	1,14	1,07
Δp (bar)	10,0	11,0	12,0	13,0	14,0	15,0	16,0	17,0	18,0	19,0	20,0	21,0	22,0	23,0	24,0	25,0
$K_{\Delta p}$	1,02	0,97	0,93	0,89	0,86	0,83	0,80	0,78	0,76	0,74	0,72	0,70	0,69	0,67	0,66	0,64

In cases of subcooling of more than 15K please use additionally the correction factors on page 60 of this brochure.

Liquid Temperature entering Valve °C	Correction Factor K_t Evaporating Temperature											
	R 407C											
	+30	+25	+20	+15	+10	+5	0	-5	-10	-15	-20	-25
+55	1,20	1,21	1,23	1,26	1,28	1,31	1,34	1,37	1,40	1,63	1,98	2,42
+50	1,10	1,11	1,13	1,15	1,17	1,19	1,22	1,24	1,27	1,48	1,79	2,18
+45	1,02	1,03	1,05	1,06	1,08	1,10	1,12	1,14	1,17	1,35	1,64	2,00
+40	0,95	0,96	0,98	0,99	1,01	1,02	1,04	1,06	1,08	1,25	1,52	1,84
+35	0,89	0,90	0,92	0,93	0,94	0,96	0,98	0,99	1,01	1,17	1,41	1,71
+30	0,85	0,85	0,87	0,88	0,89	0,90	0,92	0,93	0,95	1,10	1,32	1,60
+25		0,81	0,82	0,83	0,84	0,85	0,87	0,88	0,90	1,03	1,25	1,51
+20			0,78	0,79	0,80	0,81	0,82	0,84	0,85	0,98	1,18	1,43
+15				0,75	0,76	0,77	0,78	0,80	0,81	0,93	1,12	1,35
+10					0,73	0,74	0,75	0,76	0,77	0,89	1,07	1,29
+5						0,71	0,72	0,73	0,74	0,85	1,02	1,23
0							0,69	0,70	0,71	0,81	0,98	1,18
-5								0,67	0,68	0,78	0,94	1,13
-10									0,65	0,75	0,90	1,08

Correction Factor $K_{\Delta p}$																
Δp (bar)	0,5	1,0	1,5	2,0	2,5	3,0	3,5	4,0	4,5	5,0	5,5	6,0	6,5	7,0	8,0	9,0
$K_{\Delta p}$	4,78	3,33	2,72	2,36	2,11	1,92	1,78	1,67	1,57	1,49	1,42	1,36	1,31	1,26	1,18	1,11
Δp (bar)	10,0	11,0	12,0	13,0	14,0	15,0	16,0	17,0	18,0	19,0	20,0	21,0	22,0	23,0	24,0	25,0
$K_{\Delta p}$	1,05	1,01	0,96	0,92	0,89	0,86	0,83	0,81	0,79	0,76	0,75	0,73	0,71	0,70	0,68	0,67

Liquid Temperature entering Valve °C	Correction Factor K_t Evaporating Temperature															
	R 507															
	+30	+25	+20	+15	+10	+5	0	-5	-10	-15	-20	-25	-30	-35	-40	-45
+60	1,54	1,57	1,61	1,65	1,71	1,76	1,83	1,90	1,98	2,36	2,84	3,44	4,23	5,25	6,61	8,45
+55	1,30	1,33	1,36	1,39	1,43	1,47	1,52	1,57	1,62	1,92	2,29	2,75	3,35	4,11	5,11	6,44
+50	1,15	1,17	1,19	1,22	1,24	1,28	1,31	1,35	1,40	1,64	1,95	2,33	2,81	3,43	4,23	5,29
+45	1,03	1,05	1,07	1,09	1,11	1,14	1,17	1,20	1,23	1,45	1,71	2,04	2,45	2,97	3,64	4,53
+40	0,94	0,96	0,97	0,99	1,01	1,03	1,06	1,08	1,11	1,30	1,53	1,82	2,18	2,63	3,22	3,98
+35	0,87	0,88	0,90	0,91	0,93	0,95	0,97	0,99	1,01	1,18	1,39	1,65	1,97	2,37	2,89	3,56
+30	0,81	0,82	0,83	0,85	0,86	0,88	0,89	0,91	0,93	1,09	1,28	1,51	1,80	2,17	2,63	3,23
+25		0,77	0,78	0,79	0,80	0,82	0,83	0,85	0,87	1,01	1,18	1,40	1,66	1,99	2,42	2,97
+20			0,73	0,74	0,75	0,77	0,78	0,79	0,81	0,94	1,10	1,30	1,54	1,85	2,24	2,74
+15				0,70	0,71	0,72	0,73	0,75	0,76	0,88	1,03	1,21	1,44	1,73	2,09	2,55
+10					0,67	0,68	0,69	0,70	0,72	0,83	0,97	1,14	1,35	1,62	1,95	2,38
+5						0,64	0,65	0,67	0,68	0,78	0,92	1,07	1,27	1,52	1,83	2,23
0							0,62	0,63	0,64	0,74	0,87	1,02	1,20	1,43	1,73	2,10
-5								0,60	0,61	0,70	0,82	0,96	1,14	1,35	1,63	1,98
-10									0,58	0,67	0,78	0,91	1,08	1,28	1,54	1,87

Correction Faktor $K_{\Delta p}$																
Δp (bar)	0,5	1,0	1,5	2,0	2,5	3,0	3,5	4,0	4,5	5,0	5,5	6,0	6,5	7,0	8,0	9,0
$K_{\Delta p}$	4,63	3,27	2,67	2,31	2,07	1,89	1,75	1,64	1,54	1,46	1,40	1,34	1,28	1,24	1,16	1,09
Δp (bar)	10,0	11,0	12,0	13,0	14,0	15,0	16,0	17,0	18,0	19,0	20,0	21,0	22,0	23,0	24,0	25,0
$K_{\Delta p}$	1,03	0,99	0,94	0,91	0,87	0,85	0,82	0,79	0,77	0,75	0,73	0,71	0,70	0,68	0,67	0,65

In cases of subcooling of more than 15K please use additionally the correction factors on page 60 of this brochure.