

**Enlever le  
Filtre  
AVANT  
modifs  
&  
gluug**

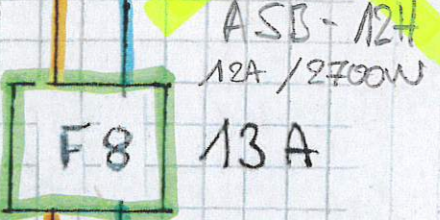

**REM** Alimente uniquement tout ce qui concerne la cde et la puissance des moteurs Cimier, Pompe + Volet

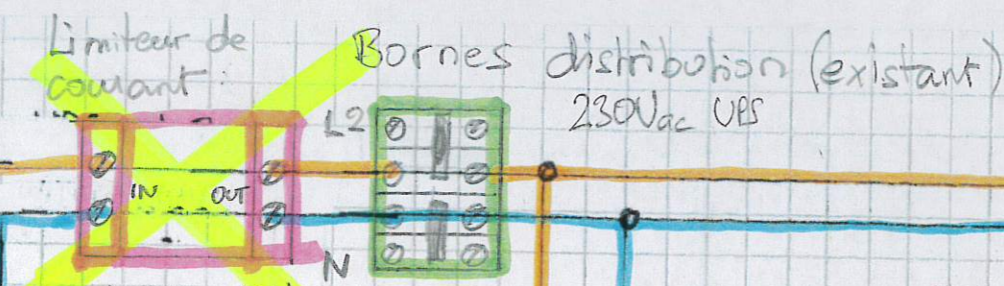
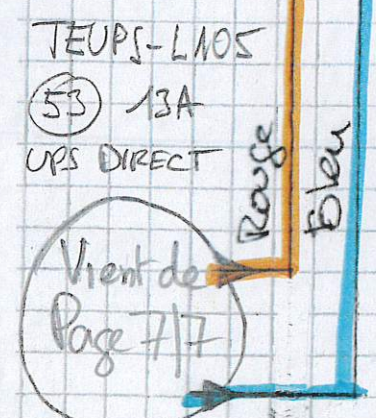

Sur L2 UPS Direct  
TEUPS-L105/53  
230V / 13A

Alimentation Relais MAN/AUTO

**RELAIS**

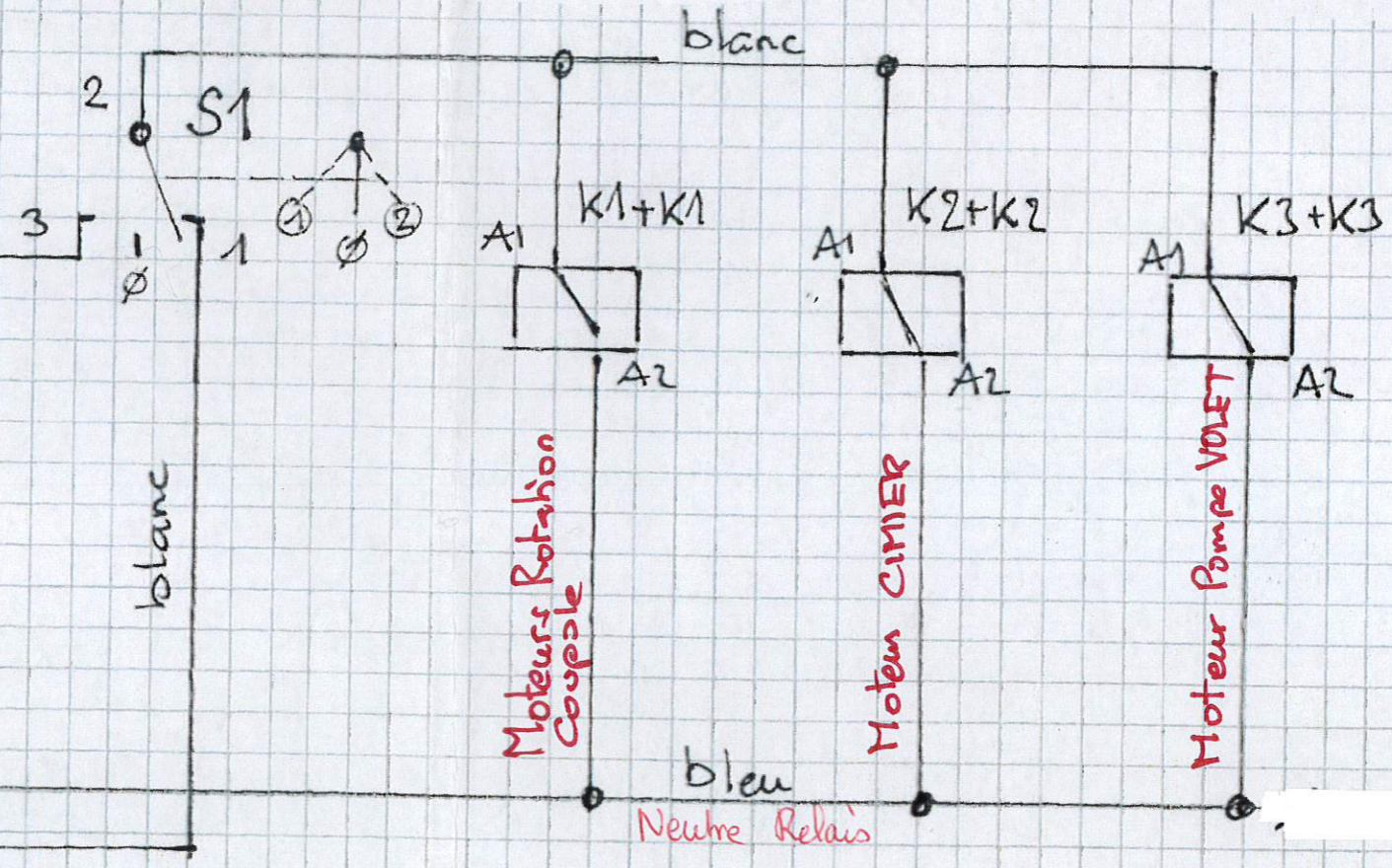

Attention le cablage des relais est fait en BLANC (cablage d'origine avant modifs 218)

**REM**  
Relais au REPOS = TELECOMMANDE (par TERC-L201)

- ① MANUEL Cde depuis TEC-L301
- ② **AUTO (Par défaut) avec Cde Diotane**
- ∅ AUTO

Terre  
Bornes

Libres	L2	N	T	55	1	2
--------	----	---	---	----	---	---

3x 2,5mm<sup>2</sup>  
230V / A  
de UPS-L201  
Pas utilisé!

2x 1,5mm<sup>2</sup>  
Cde à distance  
AUTO / MAN  
①  
②

**Pas utilisé!**

**UPS-L201** Caillebotis  
Nouvel UPS 3kVA (ou 5kVA) qui sera installé prochainement

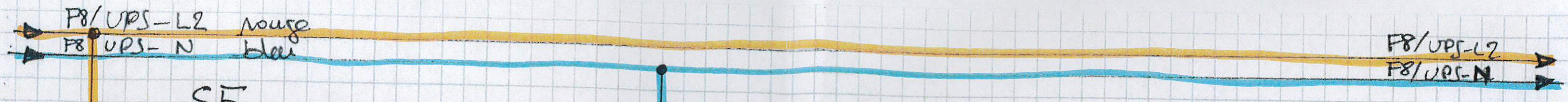

S5  
rouge 2 1  
4 3  
6 5  
Schéma 62  
Cde MAN  
CIMIER

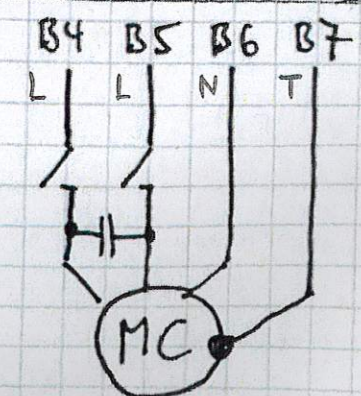
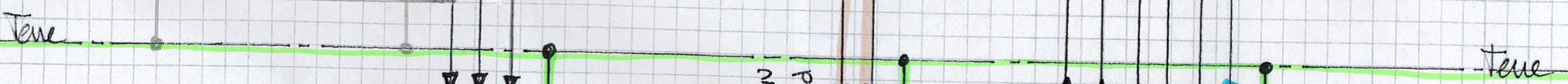
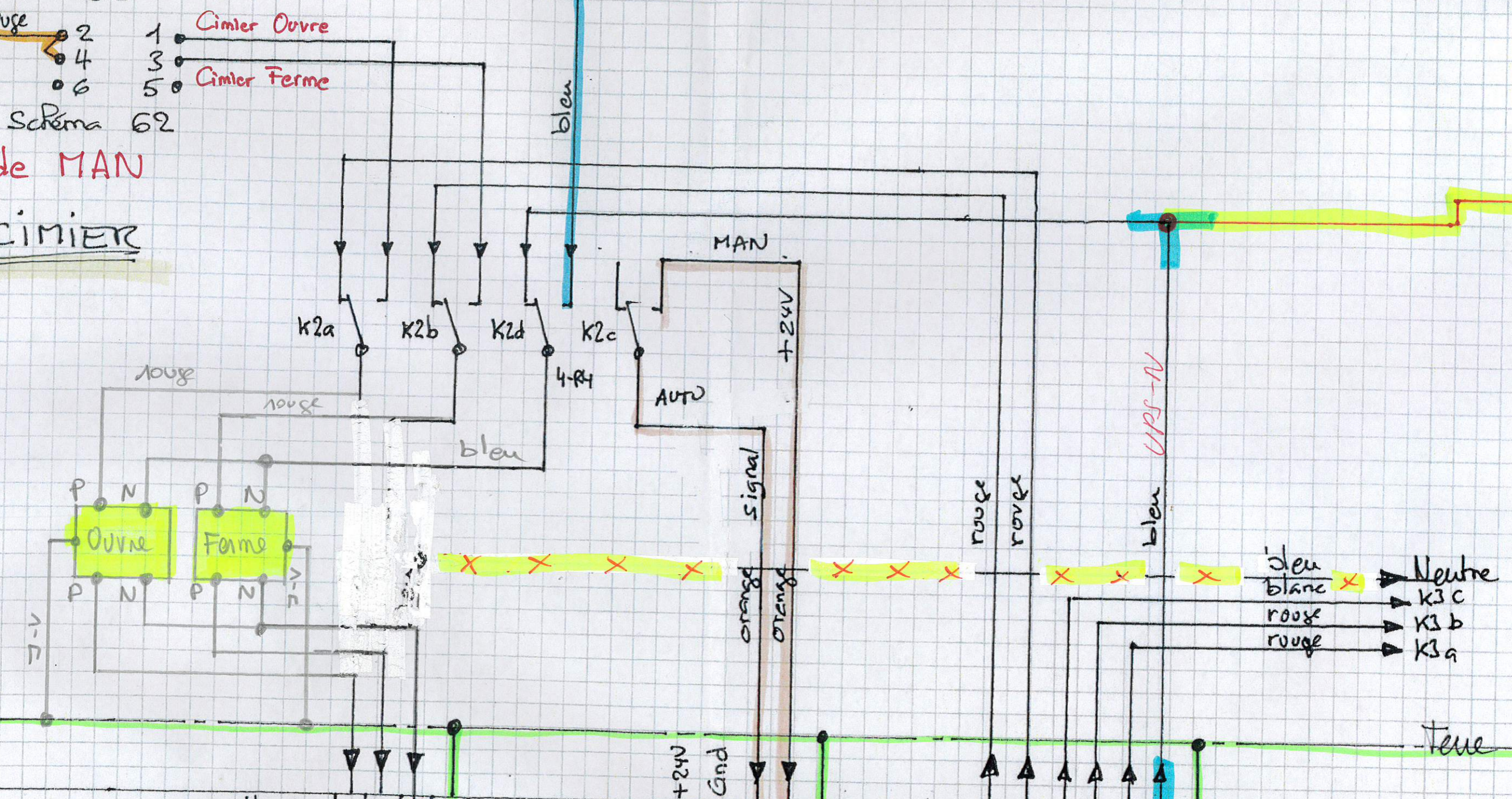

Vers Moteur Cimier  
Balais B4 B5 B6 B7  
L2 OUVRE  
L2 FERME  
Neutre  
Terre

74 | | | | |  
1 2 3 4 J-V  
5 x 2,5 mm<sup>2</sup>  
(récup) souple  
TERC-L201  
Beckhoff  
Quittance MAN/AUTO

75 | | | | |  
1 2 3 4 5 6 J-V  
7 x 1,5 mm<sup>2</sup> blindé  
L2 FERME  
L2 OUVRE  
L2 Moforce  
L2 FERME  
L2 FERME  
Retour de TERC-L201

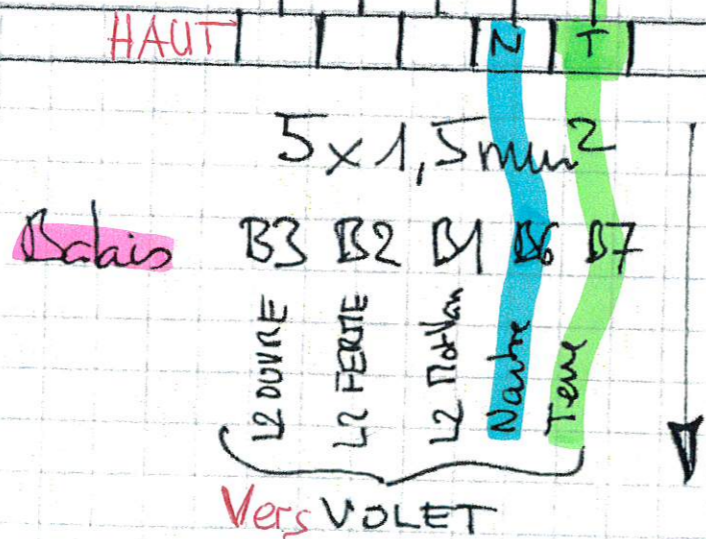
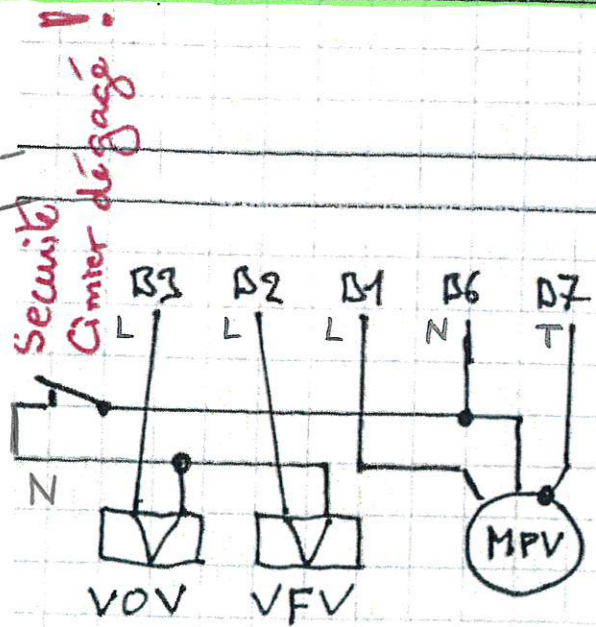
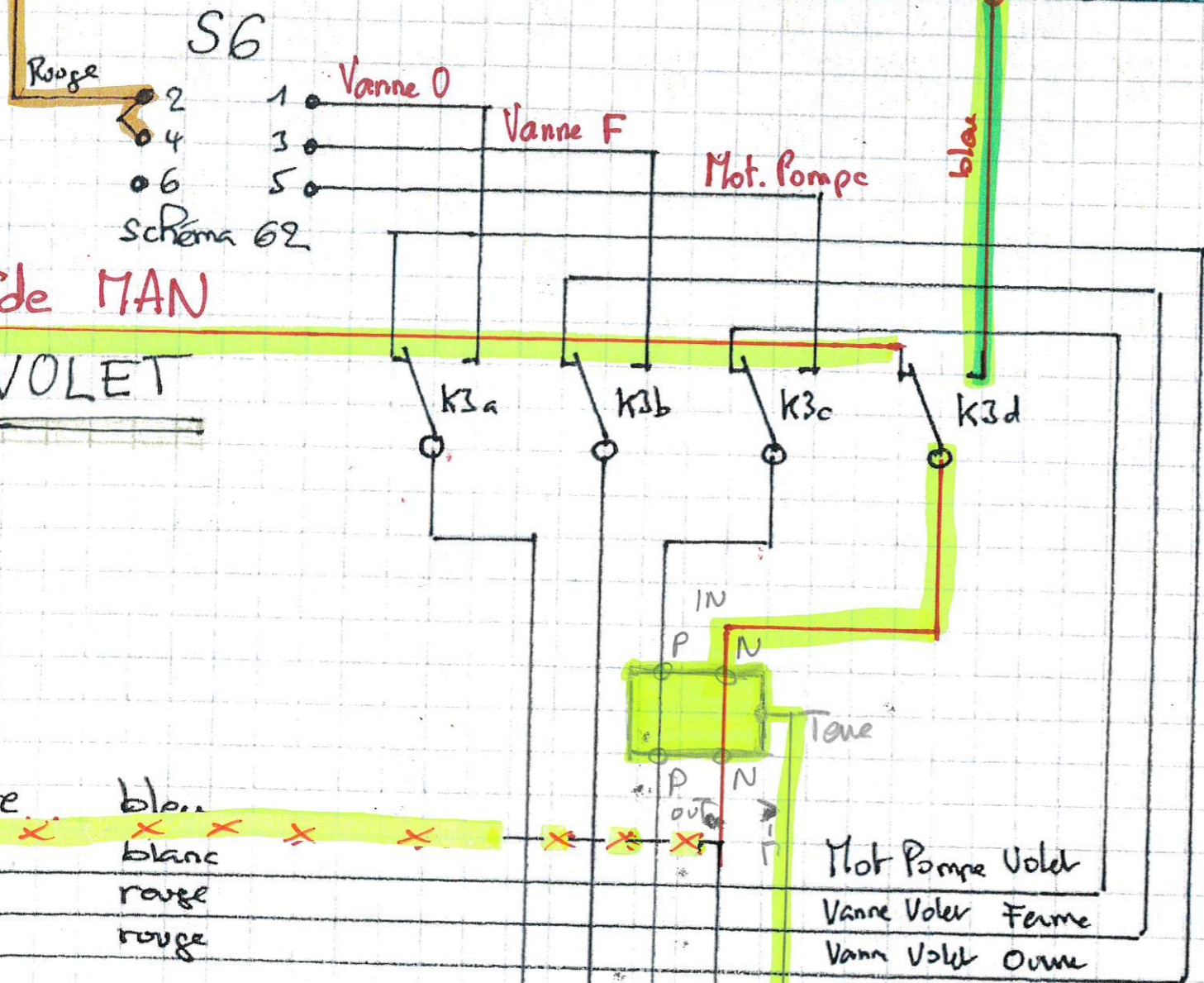
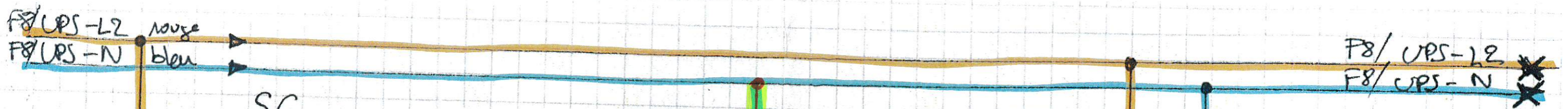

1 2 3 4 5 6  
 5 x 1,5 mm<sup>2</sup> blindé  
 TERC-L201  
 Alim UPS 230V/13A

Alim contacts  
 relais pour moteurs  
 commande par  
 Seelhoff